



BRAKE SYSTEMS FOR EOT CRANES

SAFETY

Made in Germany

BRAKE SYSTEMS FOR EOT CRANES

PINTSCH BUBENZER

CONTENT

Thruster Disc Brakes	3 - 16
Pneumatic Disc Brakes	17 - 24
Hydraulic Disc Brakes	25 - 43
Electromagnetic Disc Brakes	45 - 65
Drum Brakes, Band Brakes	67 - 83
Couplings, Hubs, Discs, Drums	85 - 101
Monitoring Systems, Control Systems	102 - 115
Storm Brakes	117 - 124
Buffers	125 - 132

Disc Brake SB 28.3 / SB 23.3 with BUEL®



PINTSCH BUBENZER
is certified according to
DIN EN ISO 9001:2008

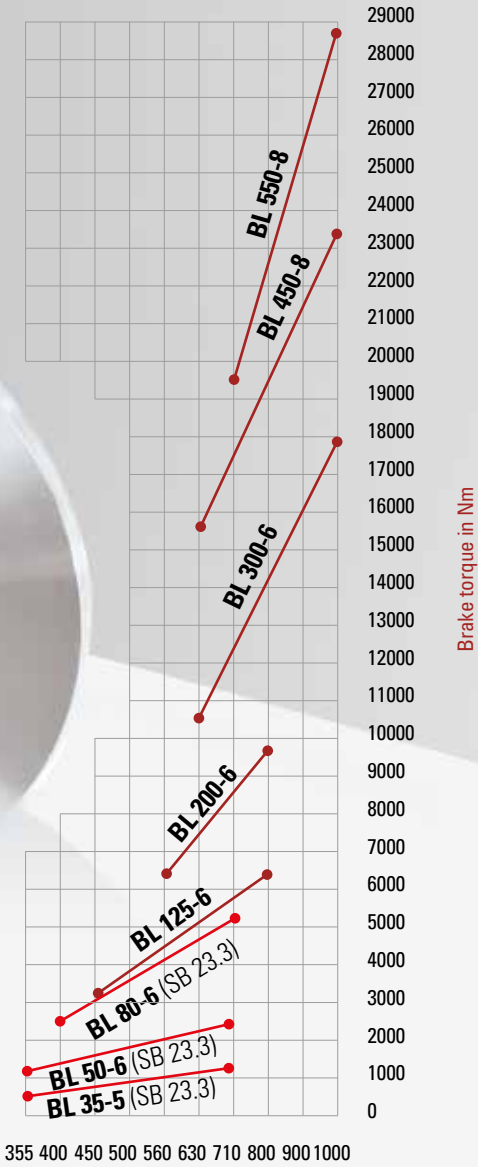

Brake disc diameter in mm



Reliable



Self-Centering



High Performance



Robust Design



Easy Maintenance

Description SB 28.3 / SB 23.3 with BUEL®



Main Features

- Limit switch release control
- Manual release lever with or without lock
- Self-centering of brake arms by cam disc and roller
- Automatic wear compensator
- Sintered linings for high friction speeds
- Continuously adjustable brake spring with torque scale and wear bushing enclosed in a spring tube
- Stainless steel pins and spindles
- Maintenance-free bushings in all hinge points
- Symmetric design
- W-execution (special anti-corrosion protection)
- Parallel air gap when brake is released (no tipping of the brake shoes)

Options

- Limit switch wear control
- Limit switch manual release
- Monitoring systems (e.g. VSR/CMB)
- Brake discs with hubs or couplings

Ordering Example

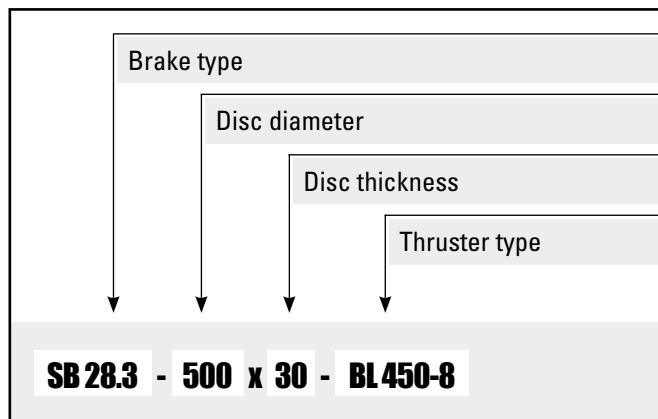

BUEL® Thrusters, Technical Data

Thruster Type	Power (W)	Curr. (A) at 400 V	Weight (kg)
BL 35-5	350	0,6	16
BL 50-6	450	0,7	16
BL 80-6	600	1,3	21
BL 125-6	650	1,4	24
BL 200-6	800	1,5	24
BL 300-6	900	1,6	33
BL 450-8	1200	2,0	33
BL 550-8	1250	2,1	33

1.5 times of nominal current



Please Note

We supply a detailed operating manual with every order. Nevertheless, we would point out that brakes are only as safe as the servicing and maintenance performed while they are in operation. The guarantee for the correct functioning of our brakes is only valid if the user adheres to the German DIN standard 15434 part 2 (drum and disc brakes, servicing and maintenance in operation), or to comparable standards in his own country.



PINTSCH BUBENZER Service

This includes the verification of the brake selection, if required. A detailed questionnaire is provided for this purpose. Installation and commissioning on-site by PINTSCH BUBENZER service engineers is possible. Drawings as DWG/ DXF files for your engineering department are available upon request.

Disc Brake SB 28.3 with BUEL®

Dimensions and technical data



Rev. 07-16

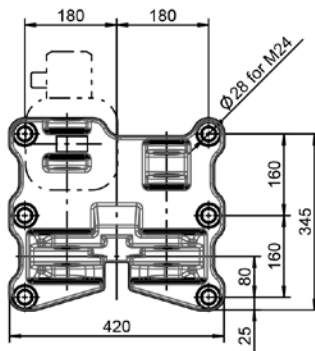
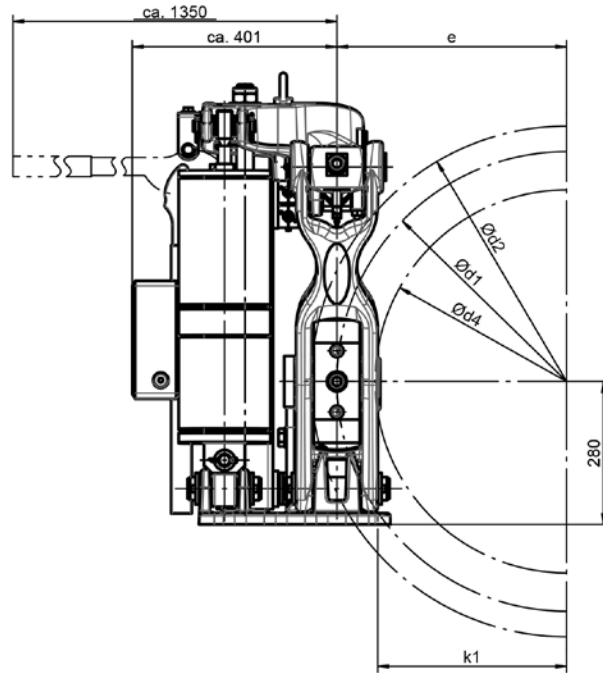
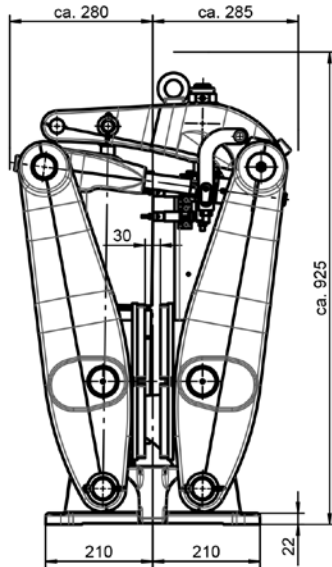

*) Average static friction factor of standard material combination

**) Only for BL 125-6 with brake disc-Ø 450 mm

The friction coefficient is subject to fluctuations depending on operational-, material- and ambient-conditions! This must be considered during the selection!

All dimensions in mm
Alterations reserved without notice

For crane brake layout use safety factors documented in the FEM 1.001, Section 1

Weight without thruster: ca. 270 kg			Thruster type		BL 125-6	BL 200-6	BL 300-6	BL 450-8	BL 550-8
			Contact force in N		22500	35000	50000	65000	80000
Disc-Ø d2	Friction-Ø d1	Max. hub-Ø d4	e	k1	Max. brake torque M_{Br} in Nm Friction factor $\mu = 0,4^*$				
450	350	175 (200**)	175	95	3150				
500	400	225	200	120	3600				
560	460	285	230	150	4140	6440			
630	530	355	265	185	4770	7420	10600		
710	610	435	305	225	5490	8540	12200	15860	19520
800	700	525	350	270	6300	9800	14000	18200	22400
900	800	625	400	320			16000	20800	25600
1000	900	725	450	370			18000	23400	28800

Disc Brake SB 23.3 with BUEL®

Dimensions and technical data



Rev. 08-16

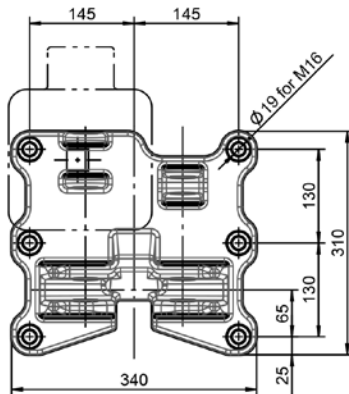
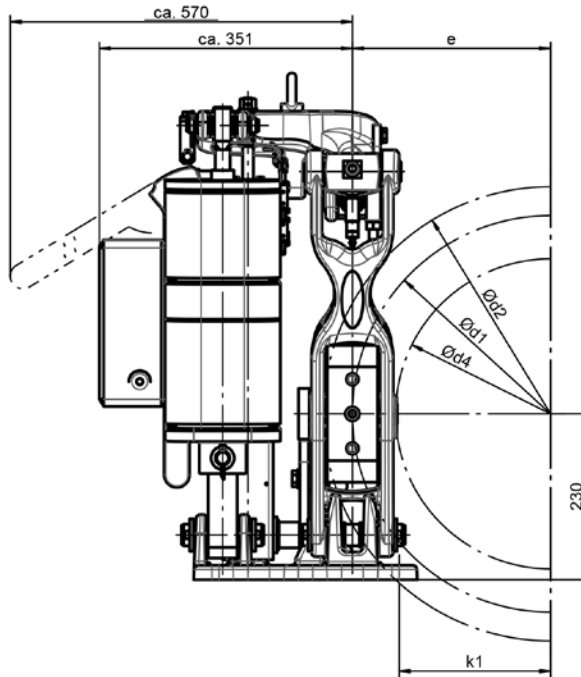
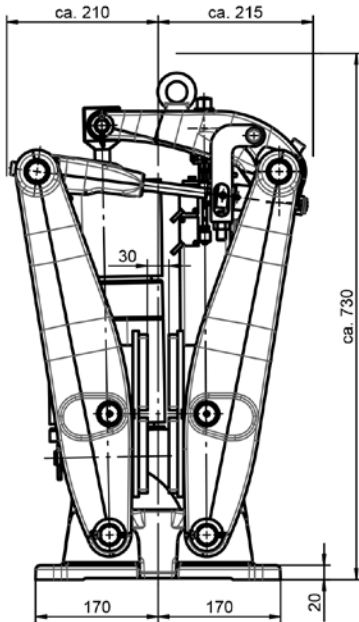

*) Average static friction factor of standard material combination

The friction coefficient is subject to fluctuations depending on operational-, material- and ambient-conditions! This must be considered during the selection!

All dimensions in mm
Alterations reserved without notice

For crane brake layout use safety factors documented in the FEM 1.001, Section 1

Weight without thruster: ca. 99 kg			Thruster type		BL 35-5	BL 50-6	BL 80-6
			Contact force in N		5000	10000	20500
Disc-Ø d2	Friction-Ø d1	Max. hub-Ø d4	e	k1	Max. brake torque M_{Br} in Nm Friction factor $\mu = 0,4^*$		
355	275	145	137,5	72,5	550	1100	
400	320	190	160	95	640	1280	2625
450	370	240	185	120	740	1480	3035
500	420	290	210	145	840	1680	3445
560	480	350	240	175	960	1920	3935
630	550	420	275	210	1100	2200	4510
710	630	500	315	250	1260	2520	5165

Disc Brake SB 16 with BUEL®



PINTSCH BUBENZER
is certified according to
DIN EN ISO 9001:2008

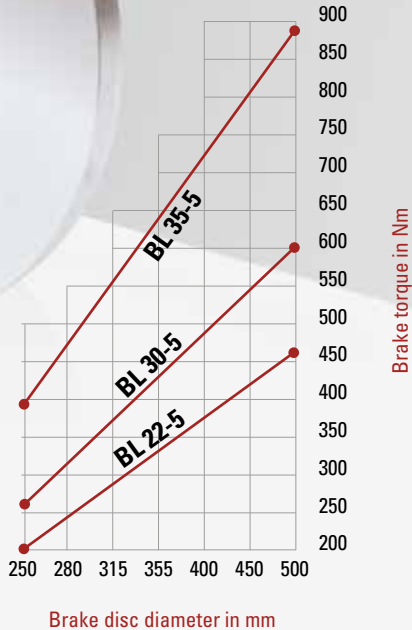

- Reliable
- Self-Centering
- High Performance
- Robust Design
- Easy Maintenance

Description SB 16 with BUEL®



Main Features

Limit switch release control
Manual release lever with or without lock
Self-centering of brake arms by cam disc and roller
Automatic wear compensator
Sintered linings for high friction speeds
Organic, non-asbestos linings for low friction speeds
Continuously adjustable brake spring with torque scale and wear bushing enclosed in a spring tube
Stainless steel pins and spindles
Maintenance-free bushings in all hinge points
Right or left-hand design
W-execution (special anti-corrosion protection)

Options

Limit switch wear control
Limit switch manual release
Monitoring systems (e.g. VSR/CMB)
Brake discs with hubs or couplings

BUEL® Thrusters, Technical Data

Thruster Type	Power (W)	Curr. (A) at 400 V	Weight (kg)
BL 22-5	150	0,4	11
BL 30-5	160	0,4	13
BL 35-5	350	0,6	16

1.5 times of nominal current

Ordering Example

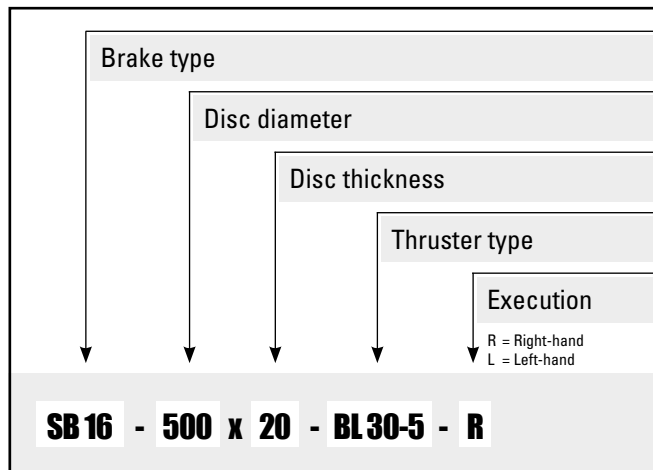

Please Note

We supply a detailed operating manual with every order. Nevertheless, we would point out that brakes are only as safe as the servicing and maintenance performed while they are in operation. The guarantee for the correct functioning of our brakes is only valid if the user adheres to the German DIN standard 15434 part 2 (drum and disc brakes, servicing and maintenance in operation), or to comparable standards in his own country.



PINTSCH BUBENZER Service

This includes the verification of the brake selection, if required. A detailed questionnaire is provided for this purpose. Installation and commissioning on-site by PINTSCH BUBENZER service engineers is possible. Drawings as DWG/ DXF files for your engineering department are available upon request.

Disc Brake SB 16 with BUEL®

Dimensions and technical data



Rev. 07-16

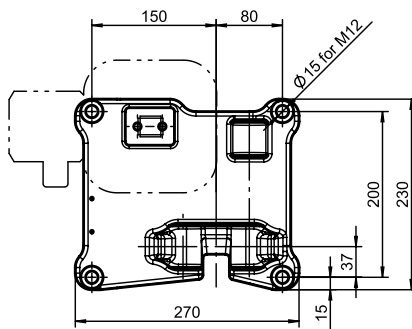
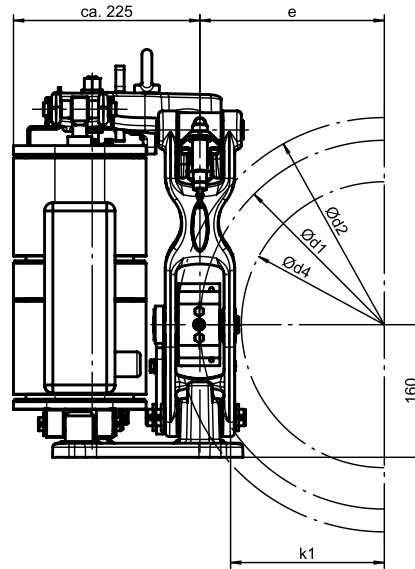
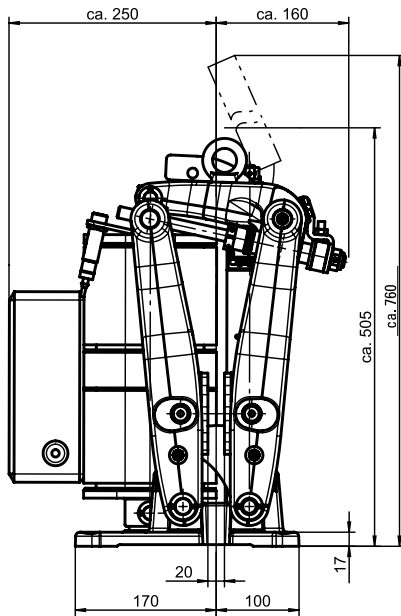

Right-hand execution

Left-hand execution

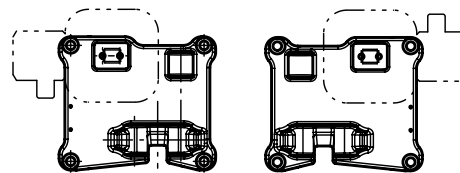

All dimensions in mm
Alterations reserved without notice

*) Average static friction factor of standard material combination

The friction coefficient is subject to fluctuations depending on operational-, material- and ambient-conditions!
This must be considered during the selection!

For crane brake layout use safety factors documented in the FEM 1.001, Section 1

Weight without thruster: ca. 37 kg			Thruster type		BL 22-5	BL 30-5	BL 35-5
			Contact force in N		2600	3400	5000
Disc-Ø d2	Friction-Ø d1	Max. hub-Ø d4	e	k1	Max. brake torque M_{Br} in Nm Friction factor $\mu = 0,4^*$		
250	195	95	97,5	60,5	205	265	390
280	225	125	112,5	75,5	235	305	450
315	260	160	130	93	270	355	520
355	300	200	150	113	310	410	600
400	345	245	172,5	135,5	360	470	690
450	395	295	197,5	160,5	410	535	790
500	445	345	222,5	185,5	465	605	890

Thruster Disc Brakes SB 8 Series



PINTSCH BUBENZER
is certified according to
DIN EN ISO 9001:2008

- 

Reliable
- 

Compact Design
- 

Robust Design
- 

Easy Maintenance

Description SB 8



Main Features

- Compact dimensions
- Ideal for belt conveyors in combination with long stroke thrusters
- Sintered linings for high friction speeds
- Organic, non-asbestos linings for low friction speeds
- Continuously adjustable brake spring with torque scale and wear bushing enclosed in a spring tube
- Stainless steel pins and spindles
- Maintenance-free bushings in all hinge points
- Right or left-hand design

Options

- Automatic wear compensator
- Limit switch release control
- Limit switch wear control
- Limit switch manual release
- Manual release lever with or without lock
- Monitoring systems (e.g. VSR/CMB)
- Brake discs with hubs or couplings

Ordering Example

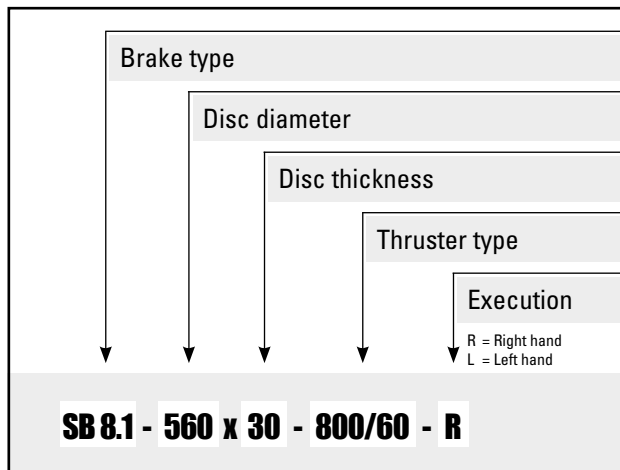

Thrusters, Technical Data

Thruster Type	Power (W)	Curr. (A) at 400 V	Weight (kg)
EB 120/40	130	0,4	7,5
EB 220/50	160	0,4	9,3
EB 300/50	140	0,3	10
EB 500/60	200	0,4	13
EB 800/60	260	0,5	19
EB 1250/60	380	0,6	21
EB 2000/60	500	0,7	33
EB 3000/60	550	0,9	39

Data supplied by thruster manufacturer, please take higher start current into consideration, fuses to be minimum 2A



Please Note

We supply a detailed operating manual with every order. Nevertheless, we would point out that brakes are only as safe as the servicing and maintenance performed while they are in operation. The guarantee for the correct functioning of our brakes is only valid if the user adheres to the German DIN standard 15434 part 2 (drum and disc brakes, servicing and maintenance in operation), or to comparable standards in his own country.



PINTSCH BUBENZER Service

This includes the verification of the brake selection, if required. A detailed questionnaire is provided for this purpose. Installation and commissioning on-site by PINTSCH BUBENZER service engineers is possible. Drawings as DWG/ DXF files for your engineering department are available upon request.

Disc Brake SB 8.11

Dimensions and technical data



Rev. 10-08

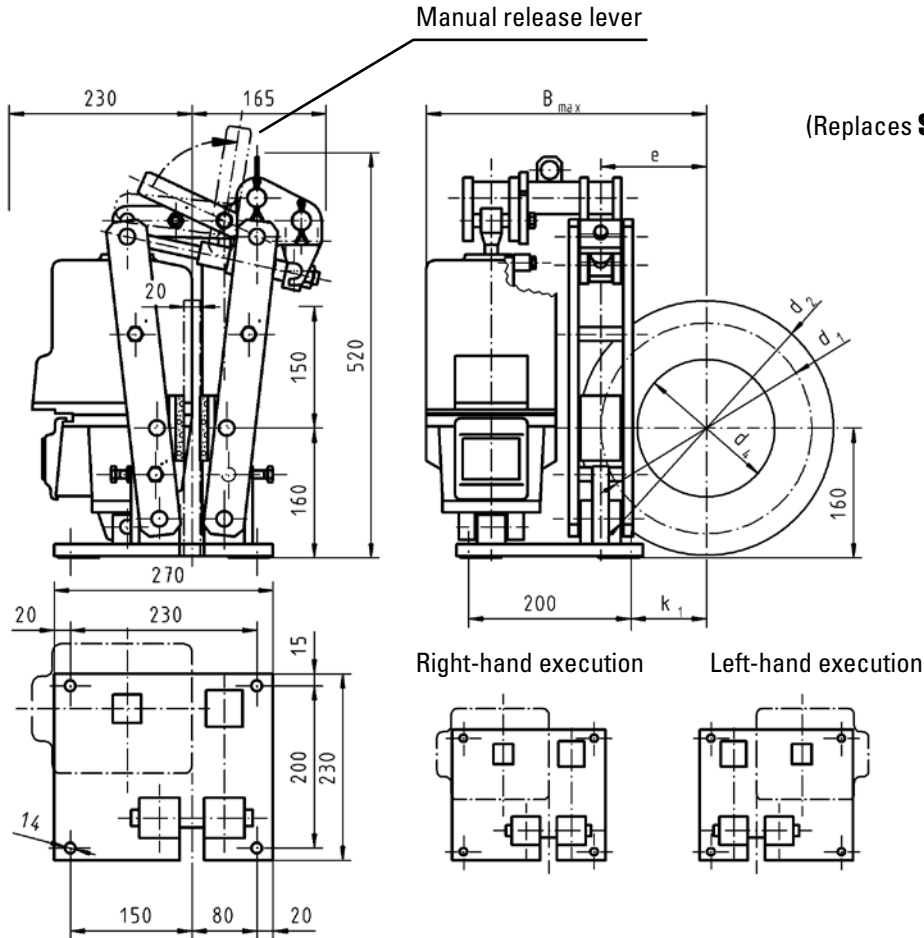

(Replaces **SB 14.11**, identical dimensions)

*) Average friction factor of standard material combination

For crane brake layout use safety factors documented in the FEM 1.001, Section 1

All dimensions in mm
Alterations reserved without notice

Weight: 37 kg w/o thruster		Thruster type				EB 120/40	EB 220/50	EB 300/50	Ed 23/5	Ed 30/5
		Contact force in N				1550	2500	3400	2500	3400
Disc Ø	Friction Ø					Brake torque M_{Br} in Nm			Friction factor $\mu = 0,4^*$	
		d_2	d_1	d_4	e	k_1	B_{max}			
250	195	105	98	61	311	120	200	270	200	270
280	225	135	113	76	326	140	230	310	230	310
315	260	170	130	93	343	160	260	355	260	355
355	300	210	150	113	363	185	300	410	300	410
400	345	255	173	136	386	215	345	470	345	470
450	395	305	197	160	411	245	395	540	395	540
500	445	355	222	185	436	275	445	610	445	610

Disc Brake SB 8.1

Dimensions and technical data



Rev. 01-08

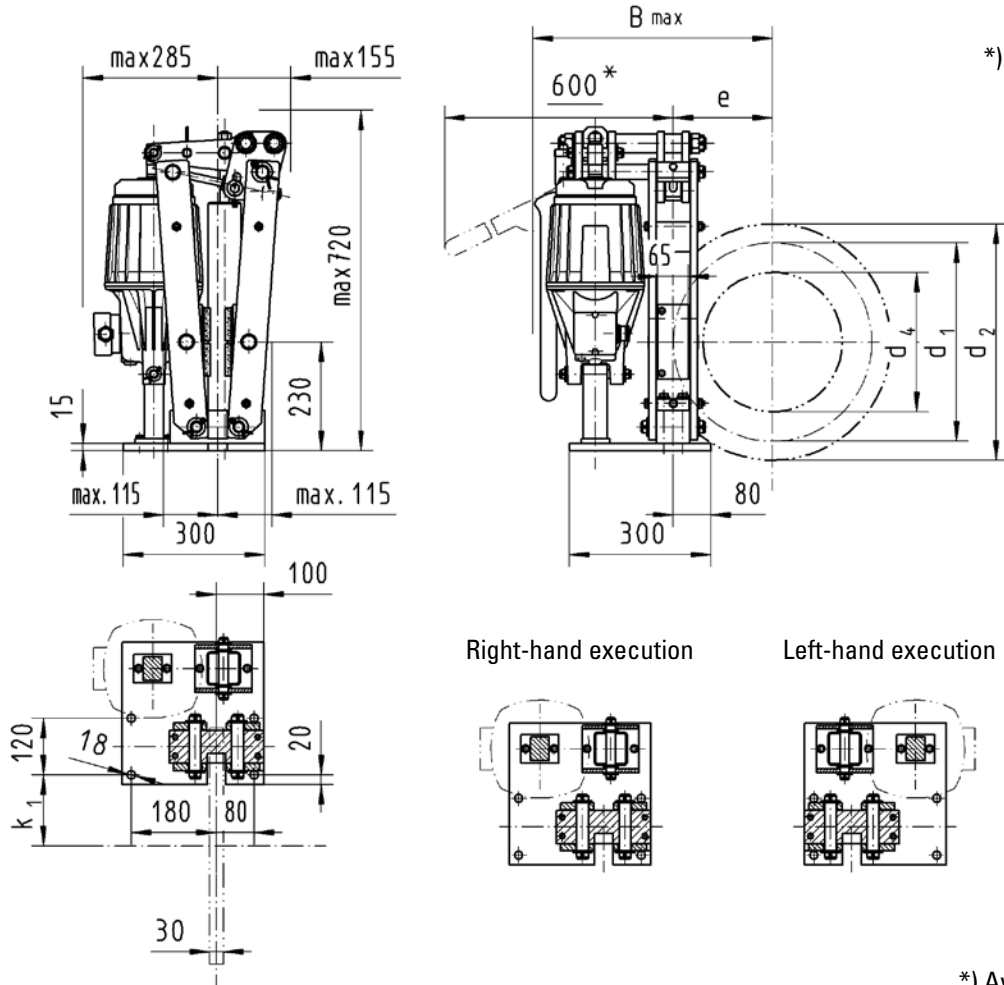

*) If ordered with manual release lever

Right-hand execution

Left-hand execution

*) Average friction factor of standard material combination

For crane brake layout use safety factors documented in the FEM 1.001, Section 1

All dimensions in mm
Alterations reserved without notice

Weight: 78 kg w/o thruster		Thruster type				EB 300/50	EB 500/60 EB 500/120	EB 800/60 EB 800/120
		Contact force in N				5950	10700	16950
Disc Ø	Friction Ø					Brake torque M_{Br} in Nm		Friction factor $\mu = 0,4^*$
d_2	d_1	d_4	e	k_1	B_{max}			
355	275	160	138	78	430	655	1180	1860
400	320	205	160	100	457	760	1370	2160
450	370	255	185	125	482	880	1580	2500
500	420	305	210	150	507	1000	1800	2840
560	480	365	240	180	537	1140	2050	3250

Disc Brake SB 8.2

Dimensions and technical data



Rev. 12-06

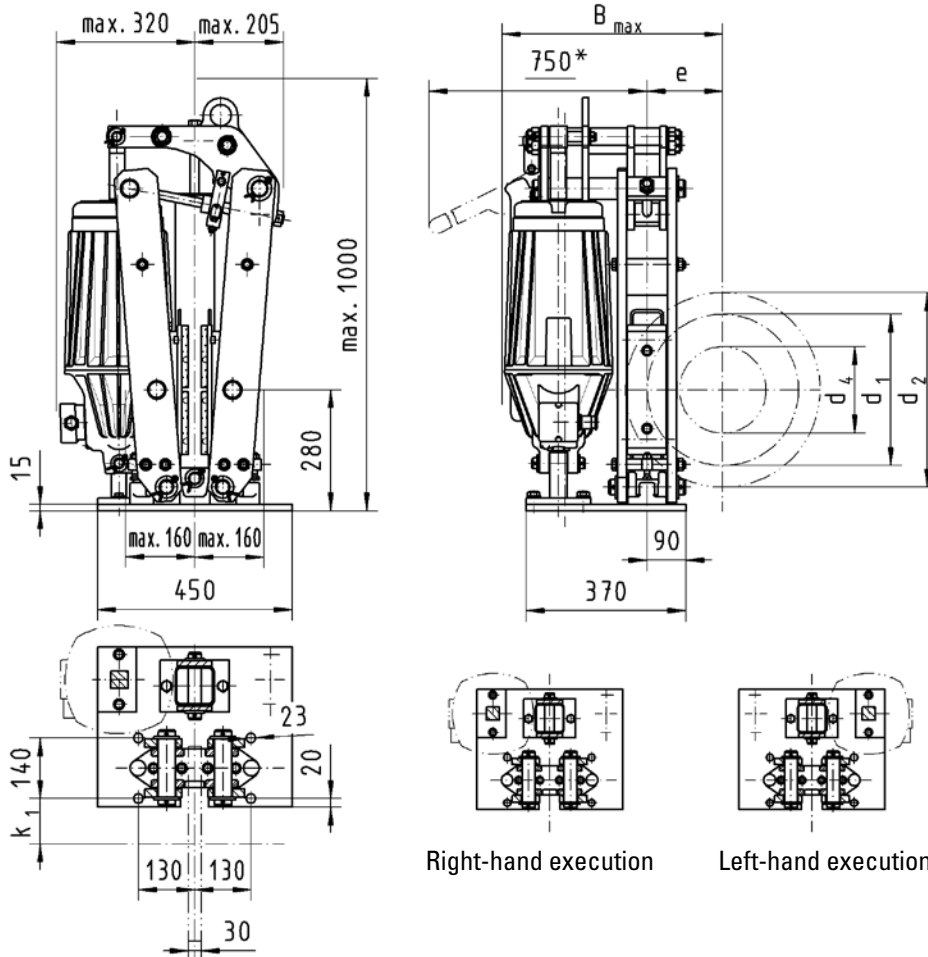

*) If ordered with manual release lever

Right-hand execution

Left-hand execution

*) Average friction factor of standard material combination

For crane brake layout use safety factors documented in the FEM 1.001, Section 1

All dimensions in mm
Alterations reserved without notice

Weight: 180 kg w/o thruster		Thruster type				EB 500/60 EB 500/120	EB 800/60 EB 800/120	EB 1250/60 EB 1250/120	EB 2000/60 EB 2000/120
		Contact force in N				11300	18300	24500	33500
Disc Ø	Friction Ø	d ₄	e	k ₁	B _{max}	Brake torque M _{Br} in Nm		Friction factor μ = 0,4*	
						d ₂	d ₁		
450	350	200	175	105	510	1580	2560	3430	4690
500	400	250	200	130	535	1810	2930	3920	5360
560	460	310	230	160	565	2080	3370	4510	6160
630	530	380	265	195	600	2395	3880	5190	7100
710	610	460	305	235	640	2760	4465	5980	8175

Disc Brake SB 8.3

Dimensions and technical data



Rev. 06-13

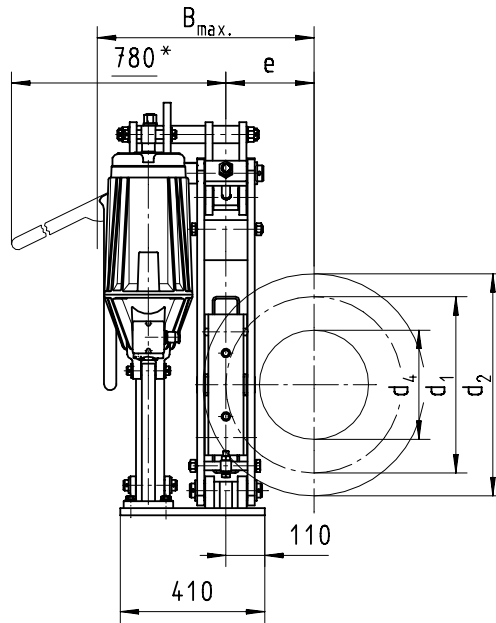
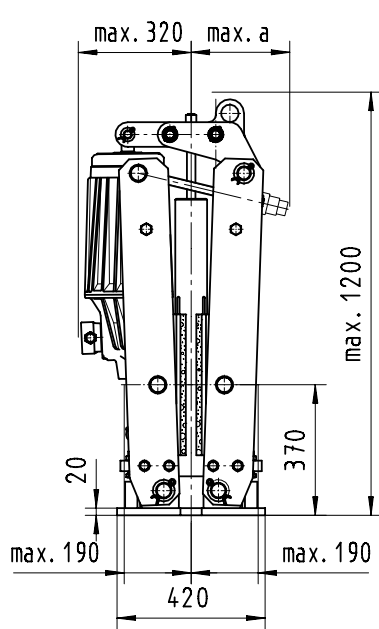

*) If ordered with manual release lever

Dimension a: With automatic wear compensator max. 280 mm
without automatic wear compensator max. 220 mm

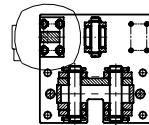
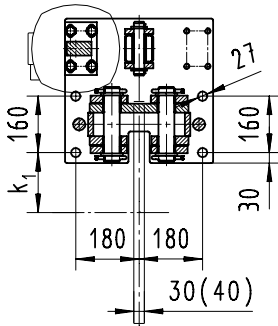

Right-hand execution

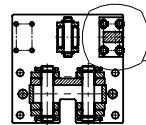

Left-hand execution

*) Average friction factor of standard material combination

For crane brake layout use safety factors documented in the FEM 1.001, Section 1

All dimensions in mm
Alterations reserved without notice

Weight: 285 kg w/o thruster		Thruster type				EB 2000/60 EB 2000/120	EB 3000/60 EB 3000/120
		Contact force in N				37400	50200
Disc Ø	Friction Ø					Brake torque M _{Br} in Nm	Friction factor μ = 0,4*
d ₂	d ₁	d ₄	e	k ₁	B _{max}		
630	500	310	250	170	615	7500	10000
710	580	390	290	210	655	8600	11600
800	670	480	335	255	700	10000	13500
900	770	580	385	305	750	11500	15500
1000	870	680	435	355	800	13000	17500
1250	1120	930	560	480	925	16750	22500

Disc Brake SB 18 PXi

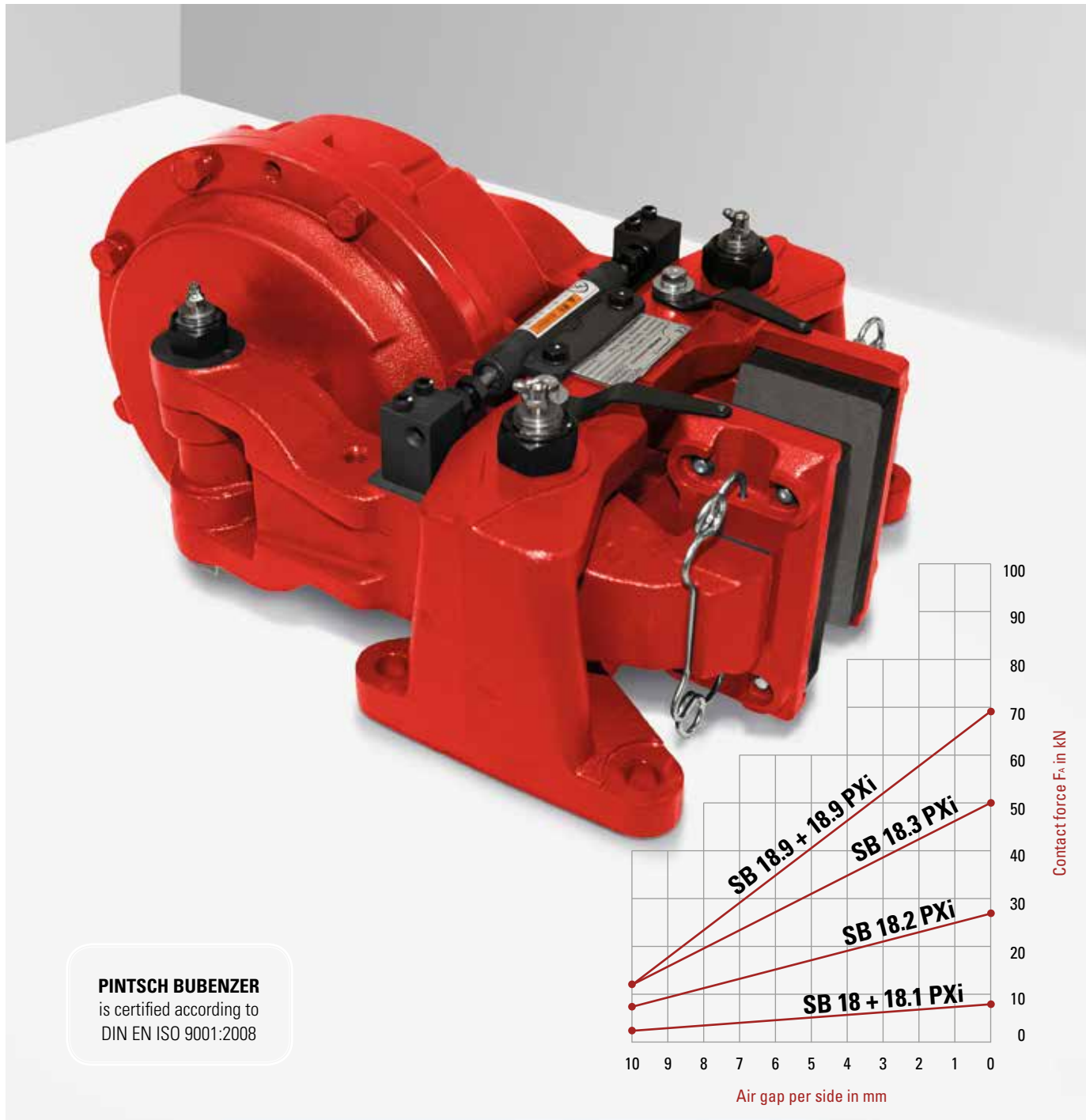

PINTSCH BUBENZER
is certified according to
DIN EN ISO 9001:2008



Reliable



High Performance



Robust Design



Easy Maintenance

Description SB 18 PXi



Main Features

Spring applied brake, released with pneumatic pressure, simple to operate with low cost control vales
Robust, reliable construction. Well proven in many industrial applications
Simple installation and adjustment for pad wear
Compliant link mechanism to maintain pad in parallel alignment at all times
Even pad wear throughout giving longer lifetime
Simple pad change using spring clips, requiring no special tools

Operating Restrictions

Requires manual adjustment of air gap to compensate for pad wear
High capacity units need lifting equipment for installation

Applications

Can be used in all industrial applications where pneumatic supply is available. Such as <ul style="list-style-type: none">• Wire and steel rope manufacturing, used as tensioners• Paper mills, tensioning and emergency• Forestry equipment, crushers
Special reference is made to the steel industry in all machines used in the process lines such as <ul style="list-style-type: none">• coilers/uncoilers• transfers• slitters• accumulators...



Please Note

We supply a detailed operating manual with every order. Nevertheless, we would point out that brakes are only as safe as the servicing and maintenance performed while they are in operation. The guarantee for the correct functioning of our brakes is only valid if the user adheres to the German DIN standard 15434 part 2 (drum and disc brakes, servicing and maintenance in operation), or to comparable standards in his own country.



PINTSCH BUBENZER Service

This includes the verification of the brake selection, if required. A detailed questionnaire is provided for this purpose. Installation and commissioning on-site by PINTSCH BUBENZER service engineers is possible. Drawings as DWG/DXF files for your engineering department are available upon request.

Disc Brake SB 18 PXi

Dimensions and technical data



Rev. 03-14

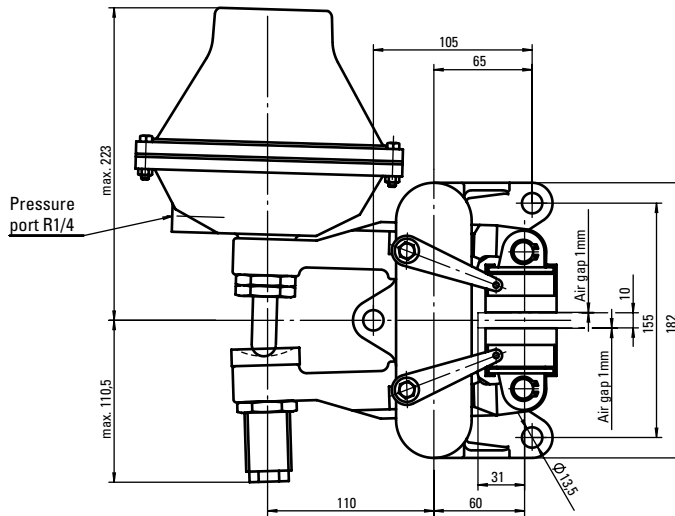
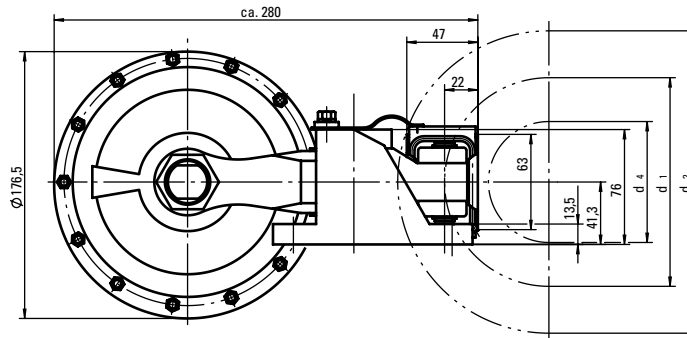

Brake torque in Nm

$$M_{BR} = F_A (N) \times \mu \times d_1 (mm) / 1000$$

All dimensions in mm
Alterations reserved without notice

*) Theoretical friction factor of standard material combination

Type		SB 18 PXi - 01	SB 18 PXi - 02
Contact force F_A at 1 mm air gap	N	7410	3840
Brake disc diameter d_2	mm	min. 200	min. 200
Friction diameter d_1	mm	$d_2 - 62$	$d_2 - 62$
Max. perm. hub diameter d_4	mm	$d_2 - 125$	$d_2 - 125$
Brake disc thickness	mm	10	10
Brake pad type		56	56
Max. pad wear (each side)	mm	3,5	3,5
Piston area	cm ²	110	110
Max. operating pressure p_{max}	bar	7	7
Theor. friction coefficient	μ^*	0,30	0,30
Weight	kg	ca. 11	ca. 11

Disc Brake SB 18.1 PXi

Dimensions and technical data



Rev. 03-14

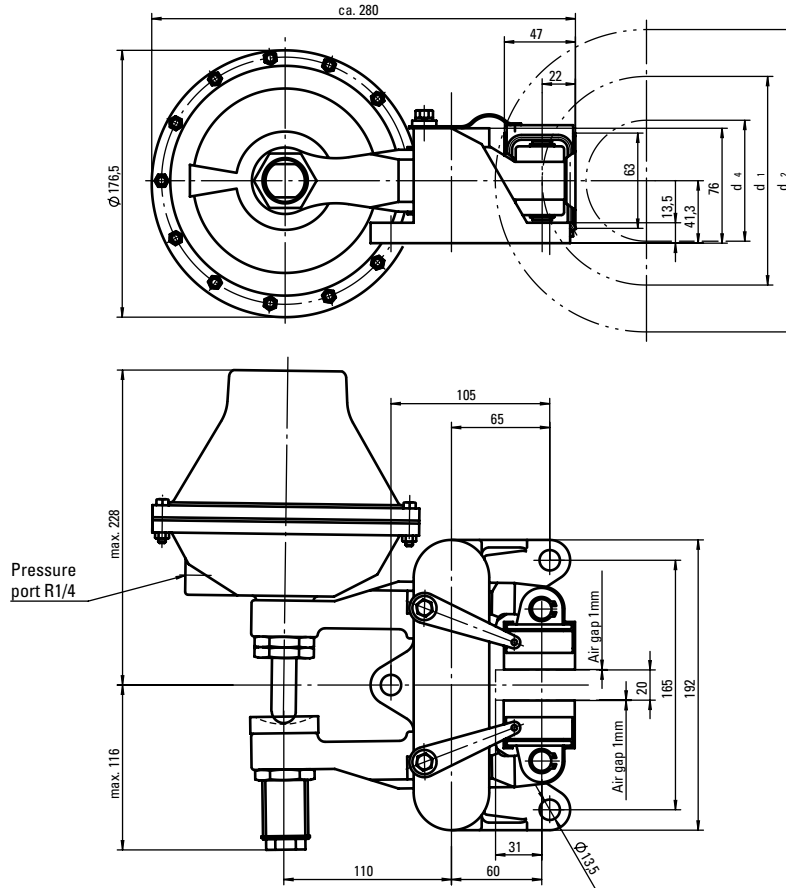

Brake torque in Nm

$$M_{BR} = F_A (N) \times \mu \times d_1 (mm) / 1000$$

All dimensions in mm
Alterations reserved without notice

*) Theoretical friction factor of standard material combination

Type		SB 18.1 PXi - 01	SB 18.1 PXi - 02
Contact force F_A at 1 mm air gap	N	7410	3840
Brake disc diameter d_2	mm	min. 200	min. 200
Friction diameter d_1	mm	$d_2 - 62$	$d_2 - 62$
Max. perm. hub diameter d_4	mm	$d_2 - 125$	$d_2 - 125$
Brake disc thickness	mm	20	20
Brake pad type		56	56
Max. pad wear (each side)	mm	3,5	3,5
Piston area	cm ²	110	110
Max. operating pressure p_{max}	bar	7	7
Theor. friction coefficient	μ^*	0,30	0,30
Weight	kg	ca. 12,5	ca. 12,5

Disc Brake SB 18.2 PXi

Dimensions and technical data



Rev. 03-14

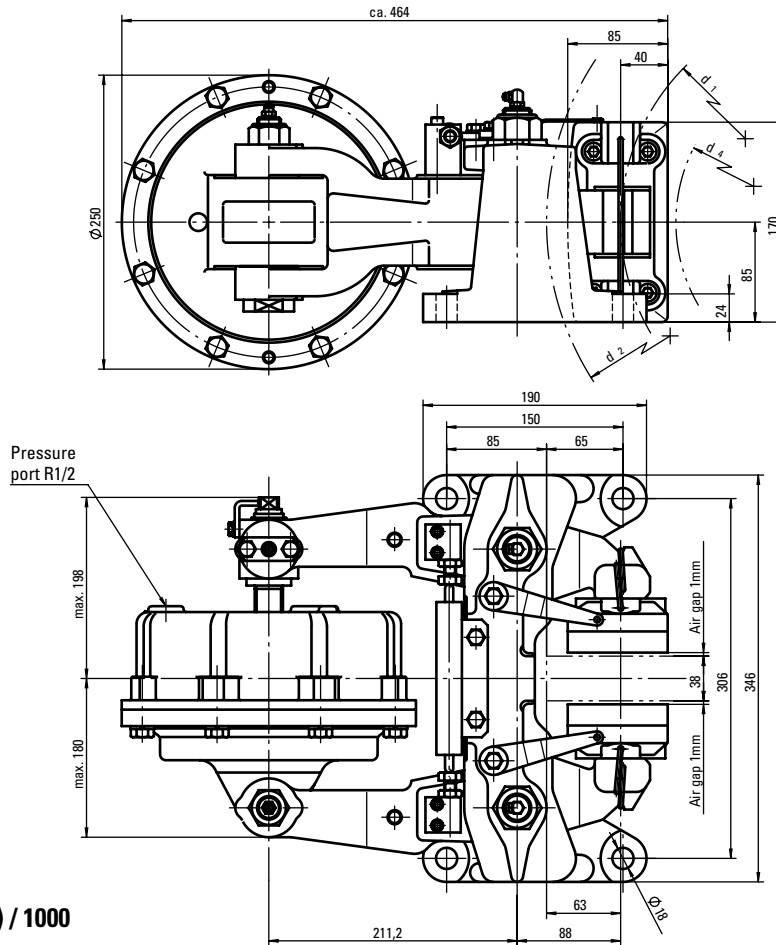

Brake torque in Nm

$$M_{BR} = F_A (N) \times \mu \times d_1 (mm) / 1000$$

All dimensions in mm
Alterations reserved without notice

*) Theoretical friction factor of standard material combination

Type		SB 18.2 PXi - 01	SB 18.2 PXi - 02	SB 18.2 PXi - 03
Contact force F_A at 1 mm air gap	N	25550	19940	14960
Brake disc diameter d_2	mm	min. 500	min. 500	min. 500
Friction diameter d_1	mm	$d_2 - 126$	$d_2 - 126$	$d_2 - 126$
Max. perm. hub diameter d_4	mm	$d_2 - 230$	$d_2 - 230$	$d_2 - 230$
Brake disc thickness	mm	38	38	38
Brake pad type		57	57	57
Max. pad wear (each side)	mm	7,5	7,5	7,5
Piston area	cm ²	301,6	301,6	301,6
Max. operating pressure p_{max}	bar	7	7	7
Theor. friction coefficient	μ^*	0,30	0,30	0,30
Weight	kg	ca. 66	ca. 66	ca. 66

Disc Brake SB 18.3 PXi

Dimensions and technical data



Rev. 03-14

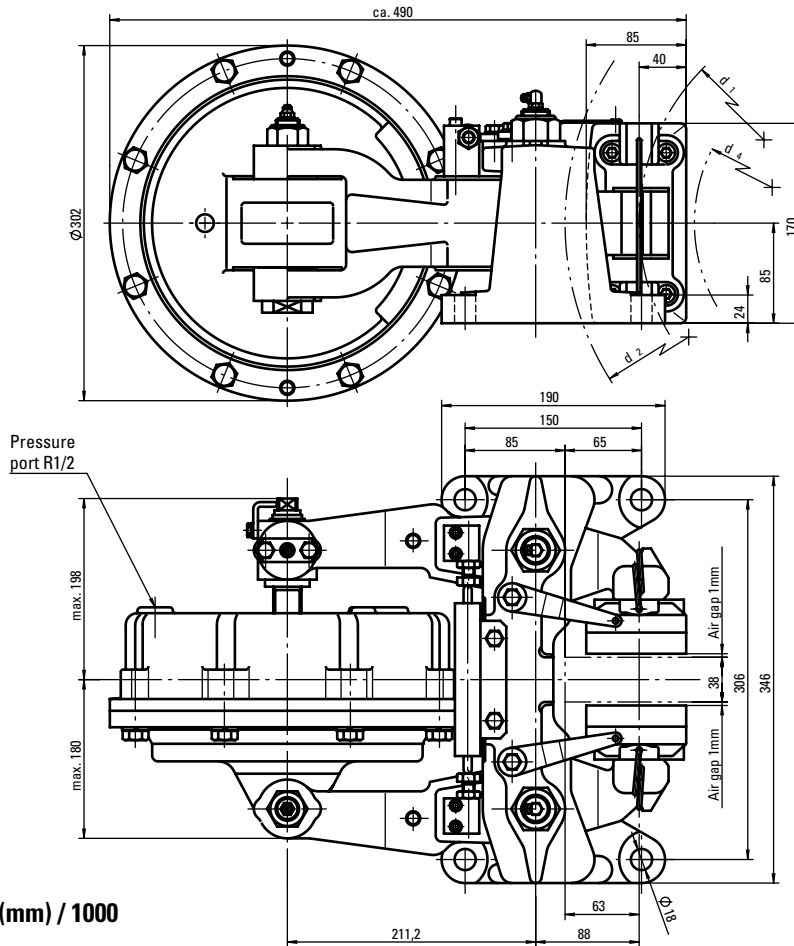

Brake torque in Nm

$$M_{BR} = F_A (N) \times \mu \times d_1 (mm) / 1000$$

All dimensions in mm
Alterations reserved without notice

*) Theoretical friction factor of standard material combination

Type		SB 18.3 PXi - 01	SB 18.3 PXi - 02	SB 18.3 PXi - 03
Contact force F_A at 1 mm air gap	N	46280	33730	22480
Brake disc diameter d_2	mm	min. 500	min. 500	min. 500
Friction diameter d_1	mm	$d_2 - 126$	$d_2 - 126$	$d_2 - 126$
Max. perm. hub diameter d_4	mm	$d_2 - 230$	$d_2 - 230$	$d_2 - 230$
Brake disc thickness	mm	38	38	38
Brake pad type		57	57	57
Max. pad wear (each side)	mm	7,5	7,5	7,5
Piston area	cm ²	478,3	478,3	478,3
Max. operating pressure p_{max}	bar	7	7	7
Theor. friction coefficient	μ^*	0,30	0,30	0,30
Weight	kg	ca. 78	ca. 78	ca. 78

Disc Brake SB 18.8 PXi

Dimensions and technical data



Rev. 03-14

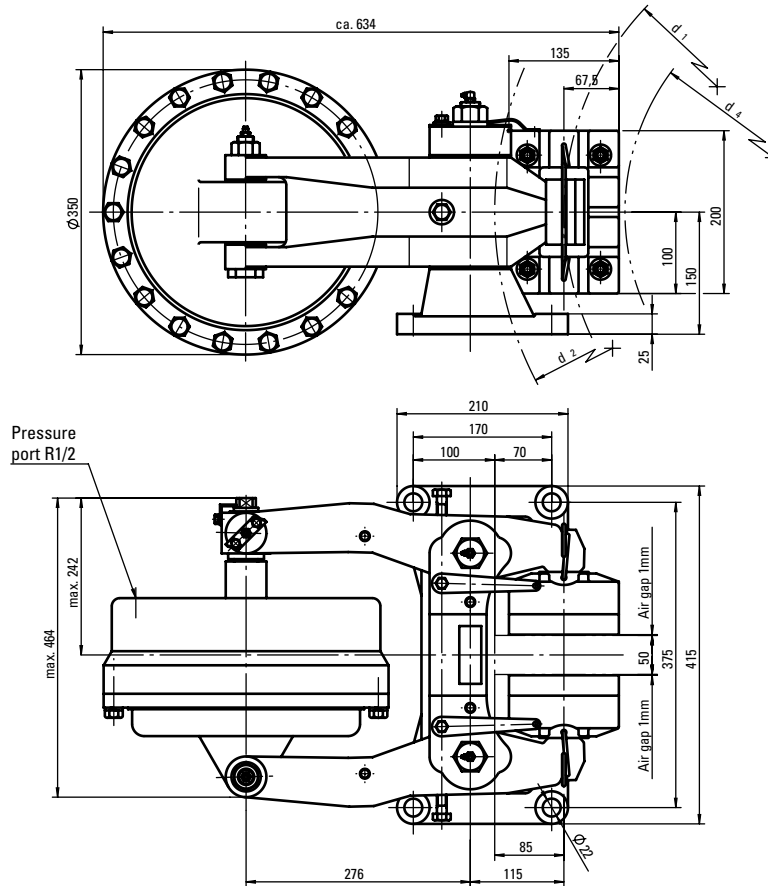

Brake torque in Nm

$$M_{BR} = F_A (N) \times \mu \times d_1 (mm) / 1000$$

All dimensions in mm
Alterations reserved without notice

*) Theoretical friction factor of
standard material combination

Type		SB 18.8 PXi - 01	SB 18.8 PXi - 02	SB 18.8 PXi - 03	SB 18.8 PXi - 04
Contact force F_A at 1 mm air gap	N	64210	55160	45660	34250
Brake disc diameter d_2	mm	min. 600	min. 600	min. 600	min. 600
Friction diameter d_1	mm	$d_2 - 170$	$d_2 - 170$	$d_2 - 170$	$d_2 - 170$
Max. perm. hub diameter d_4	mm	$d_2 - 325$	$d_2 - 325$	$d_2 - 325$	$d_2 - 325$
Brake disc thickness	mm	50	50	50	50
Brake pad type		59	59	59	59
Max. pad wear (each side)	mm	10	10	10	10
Piston area	cm ²	687	687	687	687
Max. operating pressure p_{max}	bar	7	7	7	7
Theor. friction coefficient	μ^*	0,30	0,30	0,30	0,30
Weight	kg	ca. 140	ca. 140	ca. 140	ca. 140

Disc Brake SB 18.9 PXi

Dimensions and technical data



Rev. 03-14

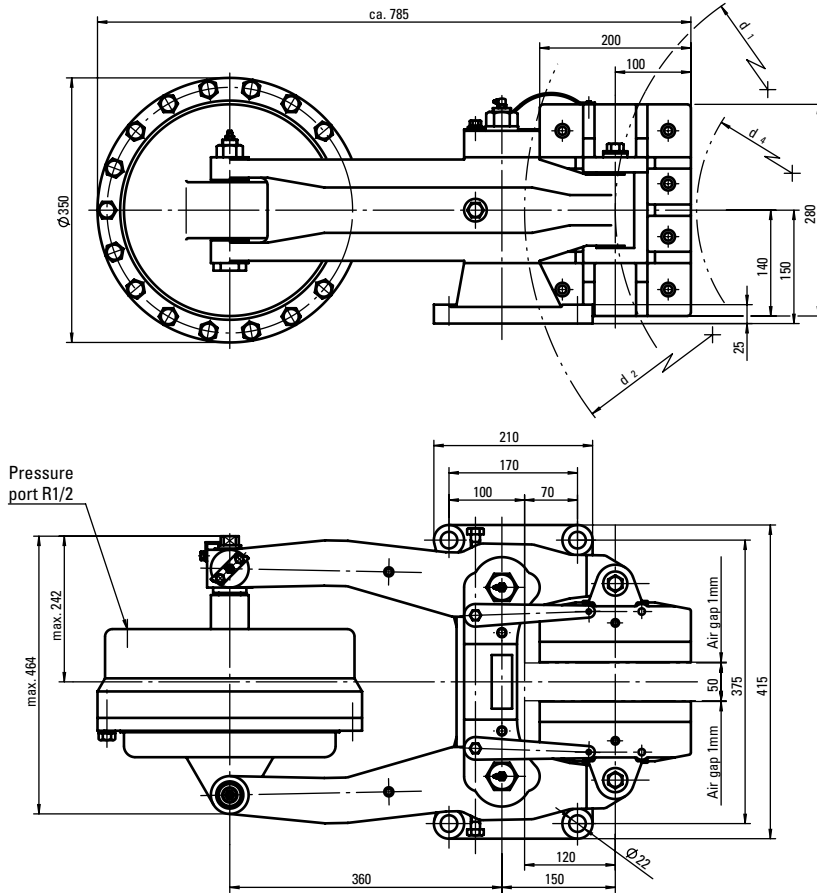

Brake torque in Nm

$$M_{BR} = F_A (N) \times \mu \times d_1 (mm) / 1000$$

All dimensions in mm
Alterations reserved without notice

*) Theoretical friction factor of standard material combination

Type		SB 18.9 PXi - 01	SB 18.9 PXi - 02	SB 18.9 PXi - 03	SB 18.9 PXi - 04
Contact force F_A at 1 mm air gap	N	64210	55160	45660	34250
Brake disc diameter d_2	mm	min. 900	min. 900	min. 900	min. 900
Friction diameter d_1	mm	$d_2 - 240$	$d_2 - 240$	$d_2 - 240$	$d_2 - 240$
Max. perm. hub diameter d_4	mm	$d_2 - 460$	$d_2 - 460$	$d_2 - 460$	$d_2 - 460$
Brake disc thickness	mm	50	50	50	50
Brake pad type		58	58	58	58
Max. pad wear (each side)	mm	10	10	10	10
Piston area	cm ²	687	687	687	687
Max. operating pressure p_{max}	bar	7	7	7	7
Theor. friction coefficient	μ^*	0,30	0,30	0,30	0,30
Weight	kg	ca. 170	ca. 170	ca. 170	ca. 170

Hydraulic Caliper Disc Brakes SF Series

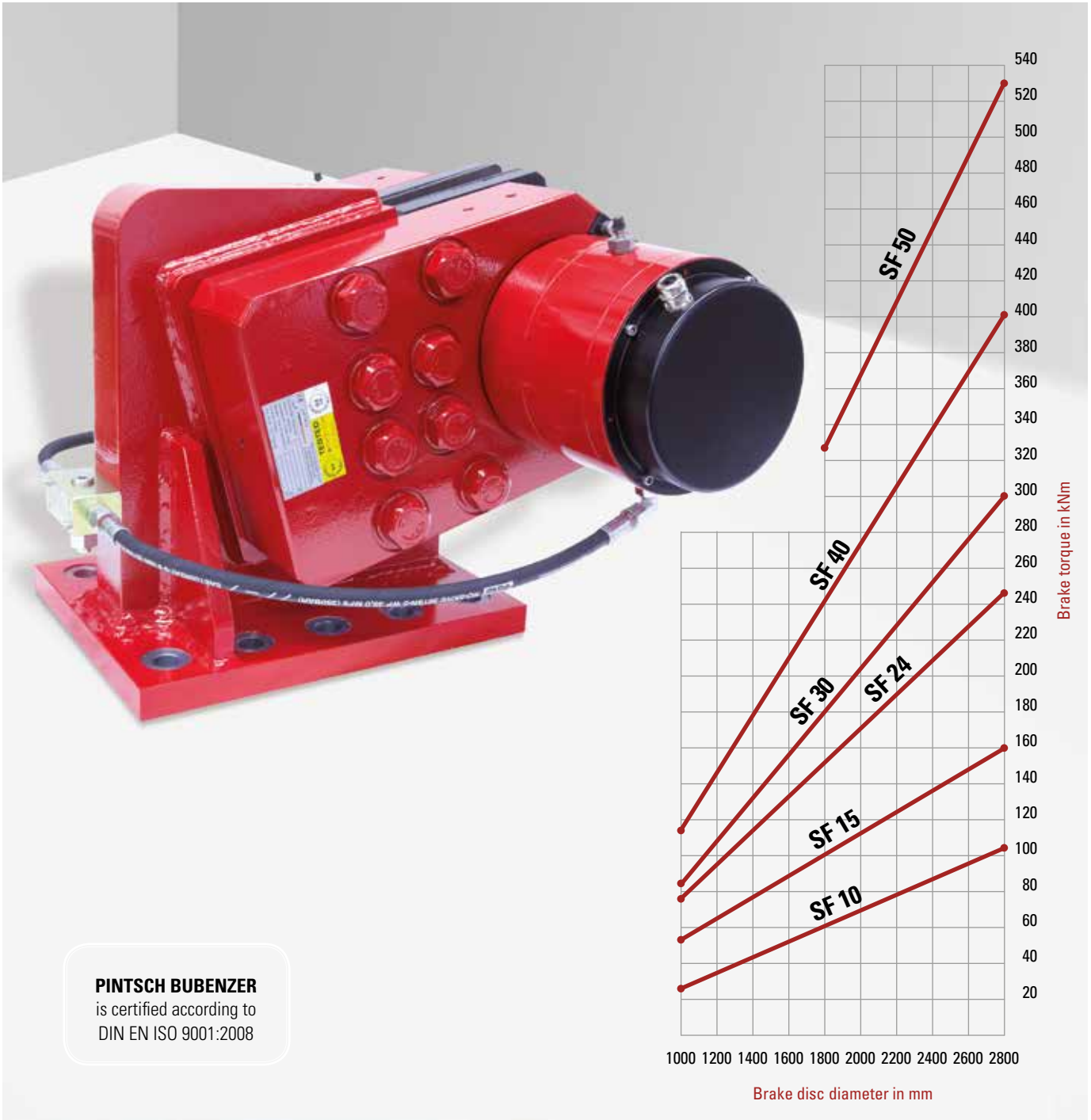

PINTSCH BUBENZER
is certified according to
DIN EN ISO 9001:2008



Reliable



High Performance



Robust Design



Easy Maintenance

Description SF



Main Features

- Two identical caliper halves, ready for operation, with spring packs set to nominal force and limit switch release control
- Up to 2 mm air gap between brake pad and disc
- Easy, manual pad wear compensation
- Organic, non-asbestos linings

Options

- Limit switch wear control
- Sintered linings
- Complete piped supports for one or more calipers
- Hydraulic power units
- Special seals for flameproof fluids
- Cleaning pads
- Brake discs
- CMB contact force measurement

Applications

- The high capacity of these brakes makes them particularly suitable as secondary emergency brakes on hoist gears and on downhill conveyor
- Other applications are possible in material handling, requiring power and compact design in either direction of rotation, particularly in replacing band brakes
- Brakes for use in high duty cycle applications are to be specifically indicated prior to the technical selection procedure**

Operating Restrictions

- Brakes of this range are tested both mechanically and hydraulically and are set to nominal force. This setting can only be changed by the manufacturer. Operating conditions other than described in this brochure require the manufacturer's approval and may influence the function of the caliper and its components



Please Note

We supply a detailed operating manual with every order. Nevertheless, we would point out that brakes are only as safe as the servicing and maintenance performed while they are in operation. The guarantee for the correct functioning of our brakes is only valid if the user adheres to the German DIN standard 15434 part 2 (drum and disc brakes, servicing and maintenance in operation), or to comparable standards in his own country.



PINTSCH BUBENZER Service

This includes the verification of the brake selection, if required. A detailed questionnaire is provided for this purpose. Installation and commissioning on-site by PINTSCH BUBENZER service engineers is possible. Drawings as DWG/DXF files for your engineering department are available upon request.

Disc Brake SF

Dimensions and technical data



Rev. 03-16

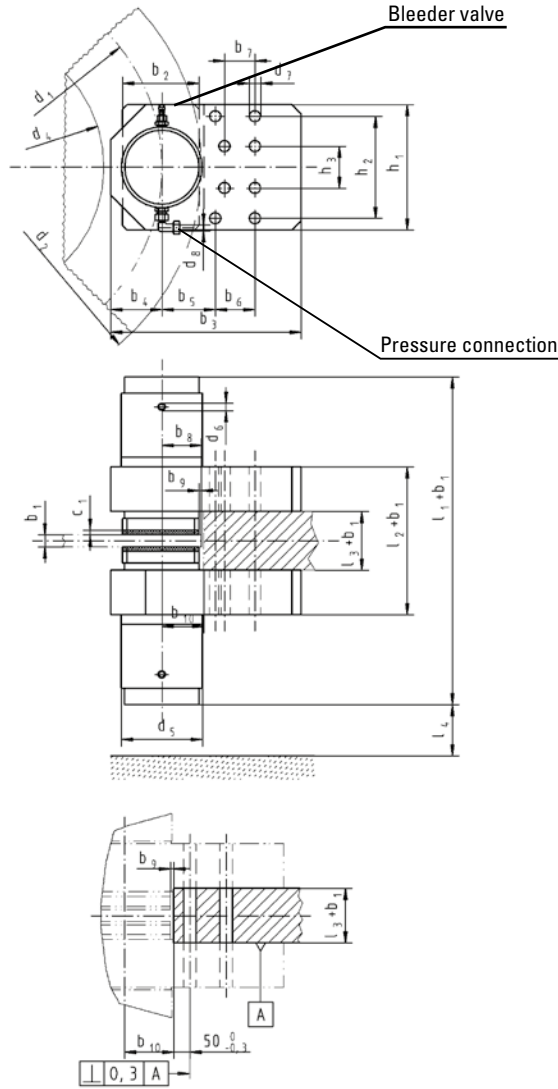

*) Average friction factor of standard material combination
All dimensions in mm. Alterations reserved without notice.

Brake torque M_{Br} in Nm = F_A (kN) x μ x d_1 (mm)

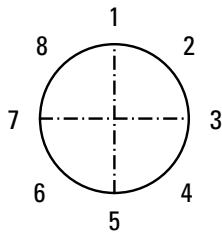

Please indicate required mounting position

Type SF	10	15	24	30	40
b_2	165	165	195	280	300
b_3	410	410	480	640	720
b_4	110	110	130	155	175
b_5	115	115	130	200	220
b_6	85	85	100	110	125
b_7	60	60	70	110	125
b_8	85	85	100	140	160
b_9	5	5	5	5	10
b_{10}	90	90	105	150	170
c_1	10	10	10	10	10
d_5	175	175	225	280	310
d_6	G1/2"	G1/2"	G1/2"	G1/2"	G1/2"
d_7	25	25	31	38	50
d_8	12	12	12	12	12
h_1	270	270	300	400	480
h_2	220	220	230	300	375
h_3	90	90	70	100	125
l_1	655	680	815	945	985
l_2	300	300	350	402	506
l_3	100	100	110	130	110
l_{4min}	110	110	130	180	200
Bolt \varnothing	M24	M24	M30	M36	M48
Bolt material	10.9	10.9	10.9	10.9	10.9
Tighten. torque, Nm	1050	1050	2100	3500	6400
Contact force F_A kN	100	150	240	300	400
Op. pressure bar	140	180	180	210	210
Max. pressure bar	200	200	200	240	240
Release stroke mm	2	2	2	2	2
Oil volume l	0,023	0,023	0,035	0,050	0,052
Pad surface cm ²	427	427	570	1050	1360
Theor. friction μ^*	0,40	0,40	0,40	0,40	0,40
Weight (kg)	200	210	368	750	1180

Data per caliper half

Brake disc data

	SF10	SF15	SF24	SF30	SF40
$d_1 = d_2$ -170 mm	d_2 -170 mm	d_2 -200 mm	d_2 -290 mm	d_2 -320 mm	
$d_4 = d_2$ -420 mm	d_2 -420 mm	d_2 -490 mm	d_2 -620 mm	d_2 -700 mm	

d_2 = Brake disc diameter in mm

d_1 = Friction diameter in mm

d_4 = Max. permissible drum or hub diameter in mm

b_1 = Disc thickness in mm (min. 30)

Disc Brake SF 50

Dimensions and technical data



Rev. 03-16

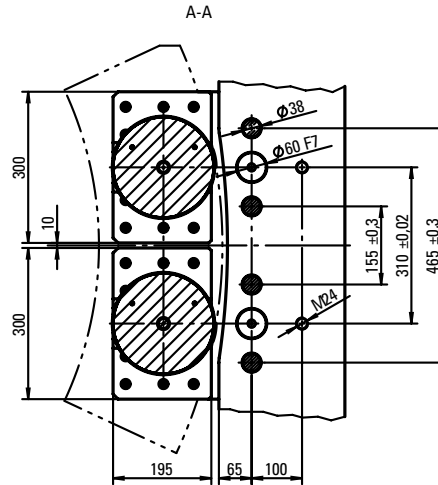
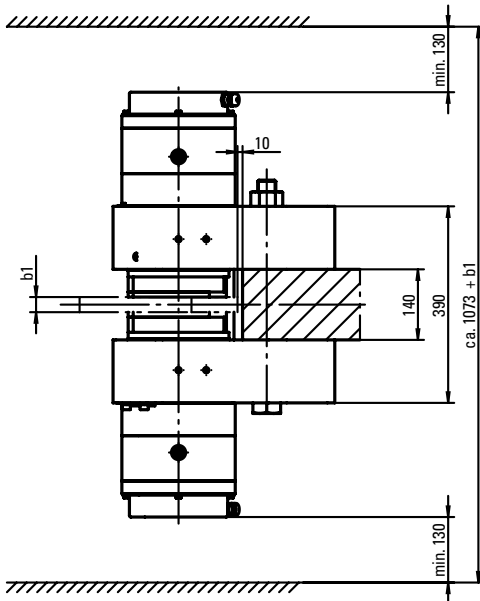
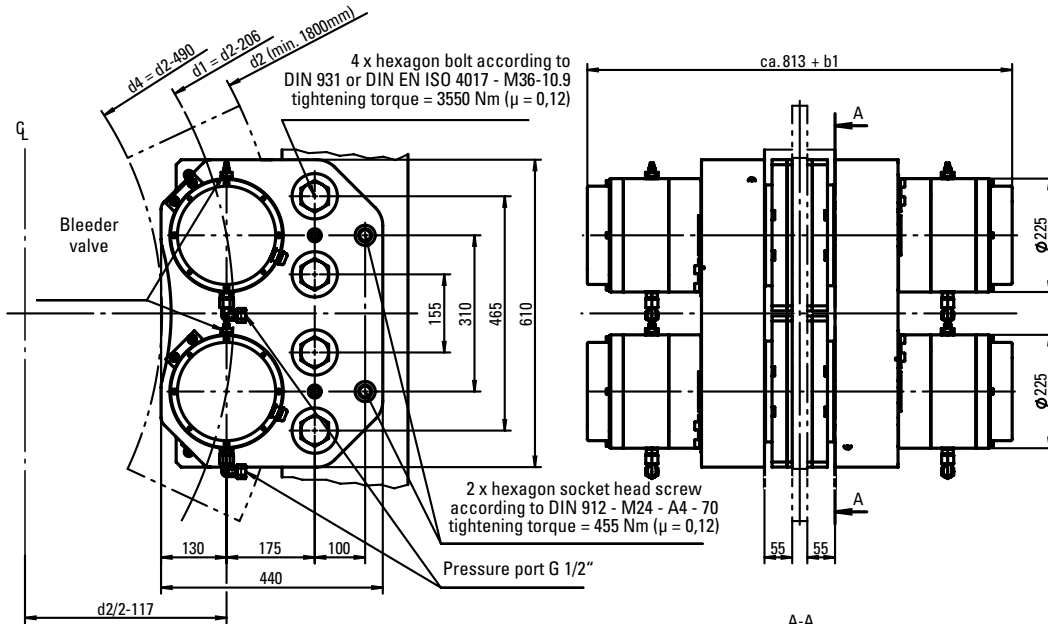

Brake Torque M_{Br} in Nm = F_A (kN) x μ x d_1 (mm)

*) Theor. friction factor of standard material combination

All dimensions in mm
Alterations reserved without notice

Type SF 50			
Data per caliper half	Contact force F_A	kN	510
	Operating pressure p	bar	200
	Max. pressure p_{max}	bar	220
	Release stroke	mm	2
	Oil volume	l	0,07
	Pad surface	cm ²	1100
	Theor. friction factor	μ^*	0,40
	Weight (without bracket)	kg	ca. 730

d_2 = Brake disc diameter in mm
 d_1 = Friction diameter in mm
 d_4 = Max. permissible drum or hub diameter in mm
 b_1 = Brake disc thickness in mm (min. 30)

Disc Brake SF

Hydraulic power unit for one or more calipers



Rev. 12-06

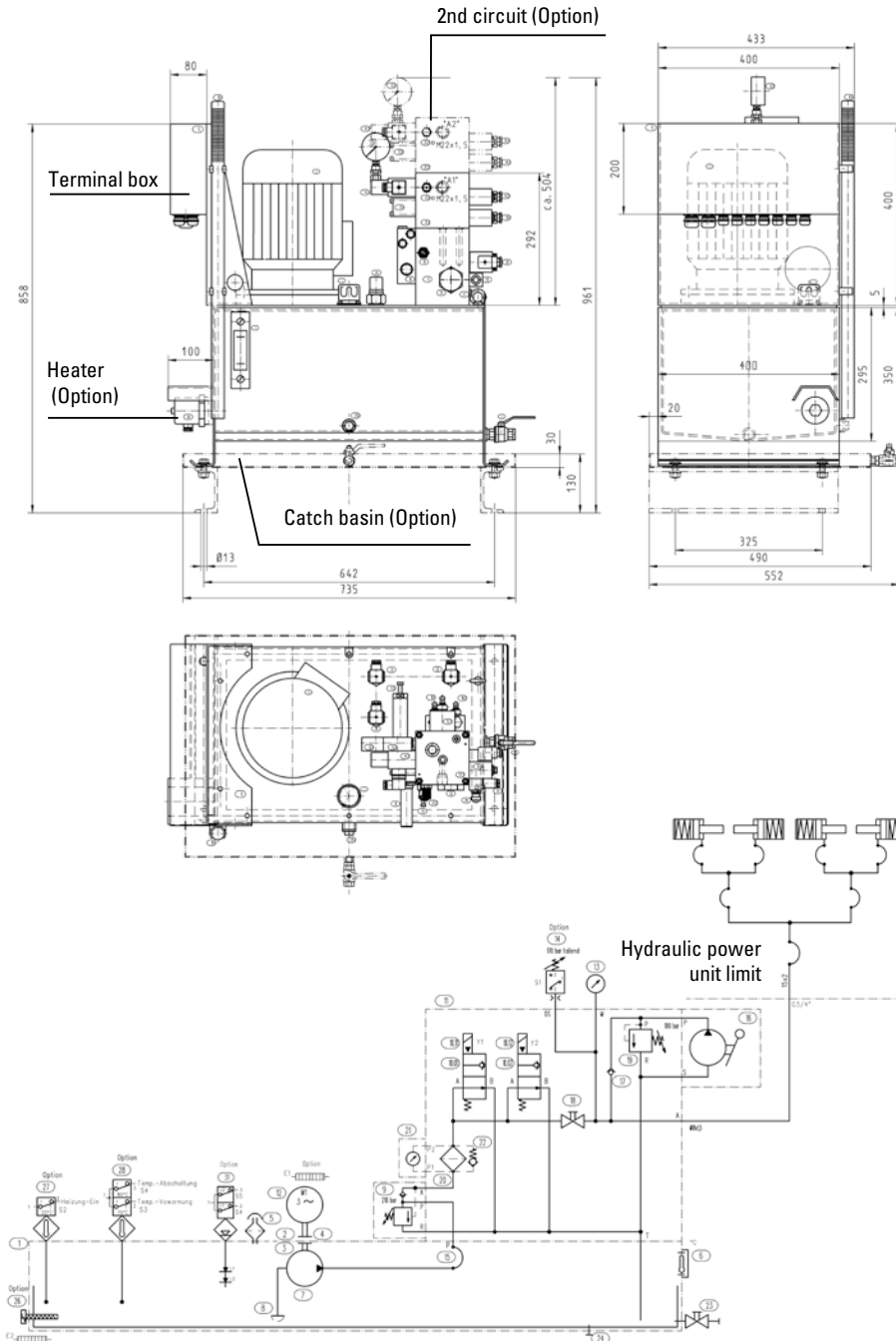

Example:	
Standard configuration	up to 4 SF10/SF15
	up to 2 SF24
Motor:	3 kW
Pump:	7,9 l/min
Pressure:	210 bar
Tank:	40 l
Weight:	85 kg

The flow diagram shows the general arrangement of the hydraulic power unit, including hand pump for emergency manual release of the brakes.

The two solenoid valves are connected in parallel (redundancy). After the nominal pressure is reached, the idler valve switches into idle running. The motor is continuously energized.

Pressure switch, temperature switch, heaters, level switch, stainless steel version and other accessories are available options.

Hydraulic power units are also available as dual-circuit power units, e.g. to operate main hoist and boom hoist brakes with one power unit only.

All dimensions in mm. Alterations reserved without notice.



We supply a complete hydraulic and electric diagram according to the order specification with every order.

Piping Samples

Disc brakes SF and BSC



Rev. 09-02

Example:

Piping of one brake unit – one hydraulic power unit

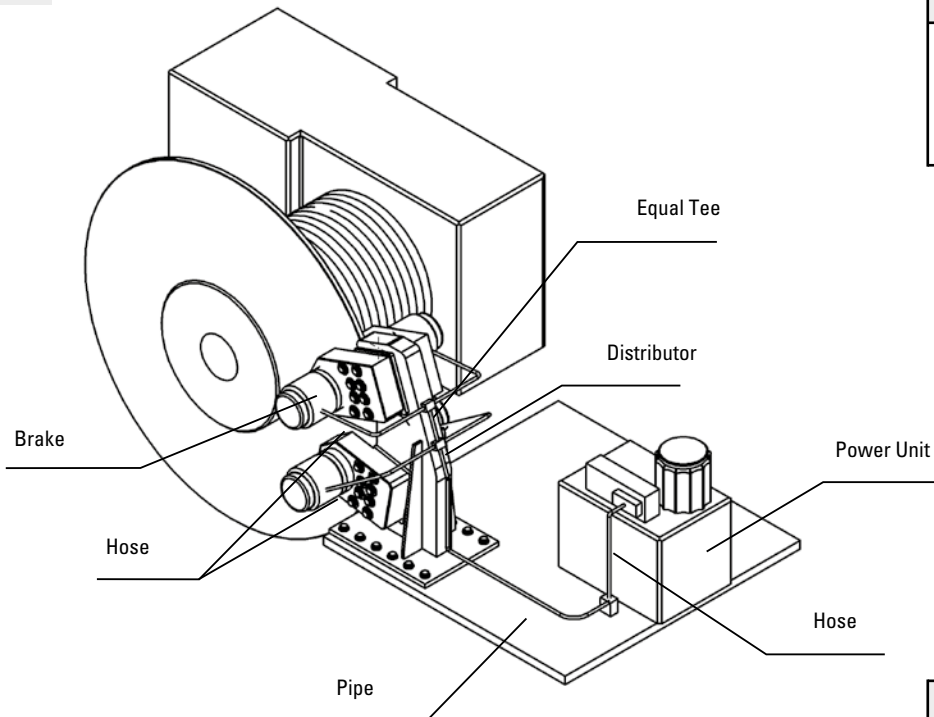

Example:

Piping of two brake units - one hydraulic power unit

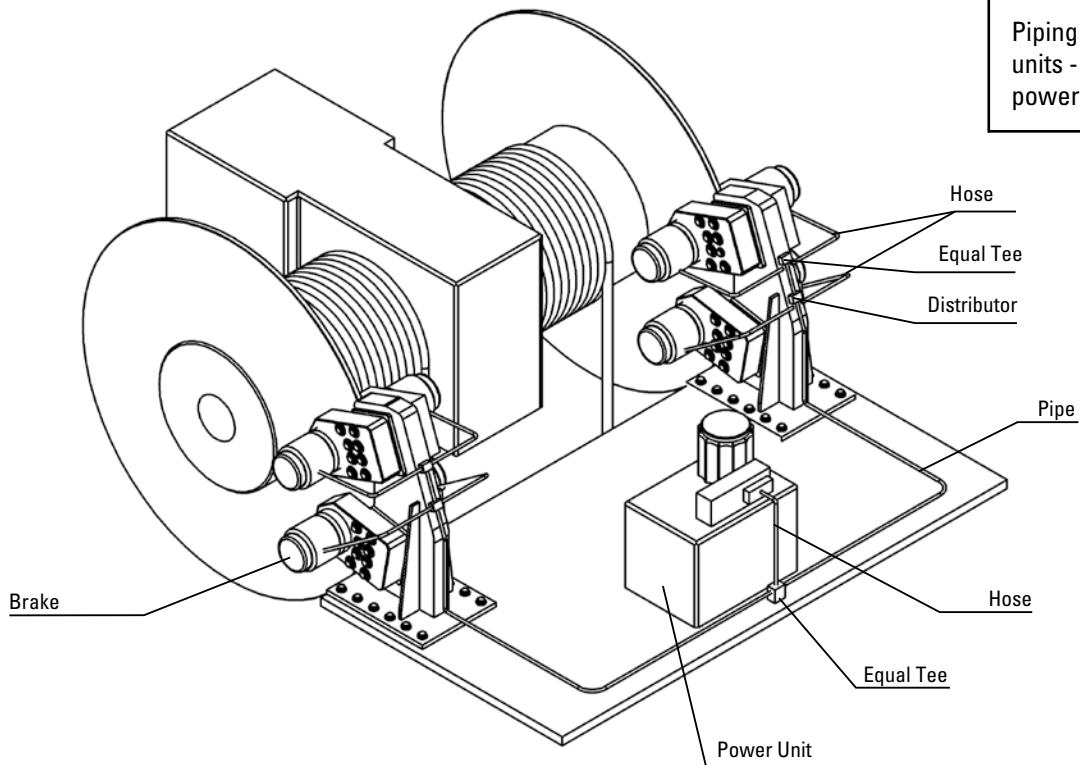

Attention: For operating two brake units with one power unit please note, that the power unit should be installed between the brakes in the centre to achieve almost equal pipe length on both sides (equal apply time of brakes).

Hydraulic Caliper Disc Brakes BSC Series

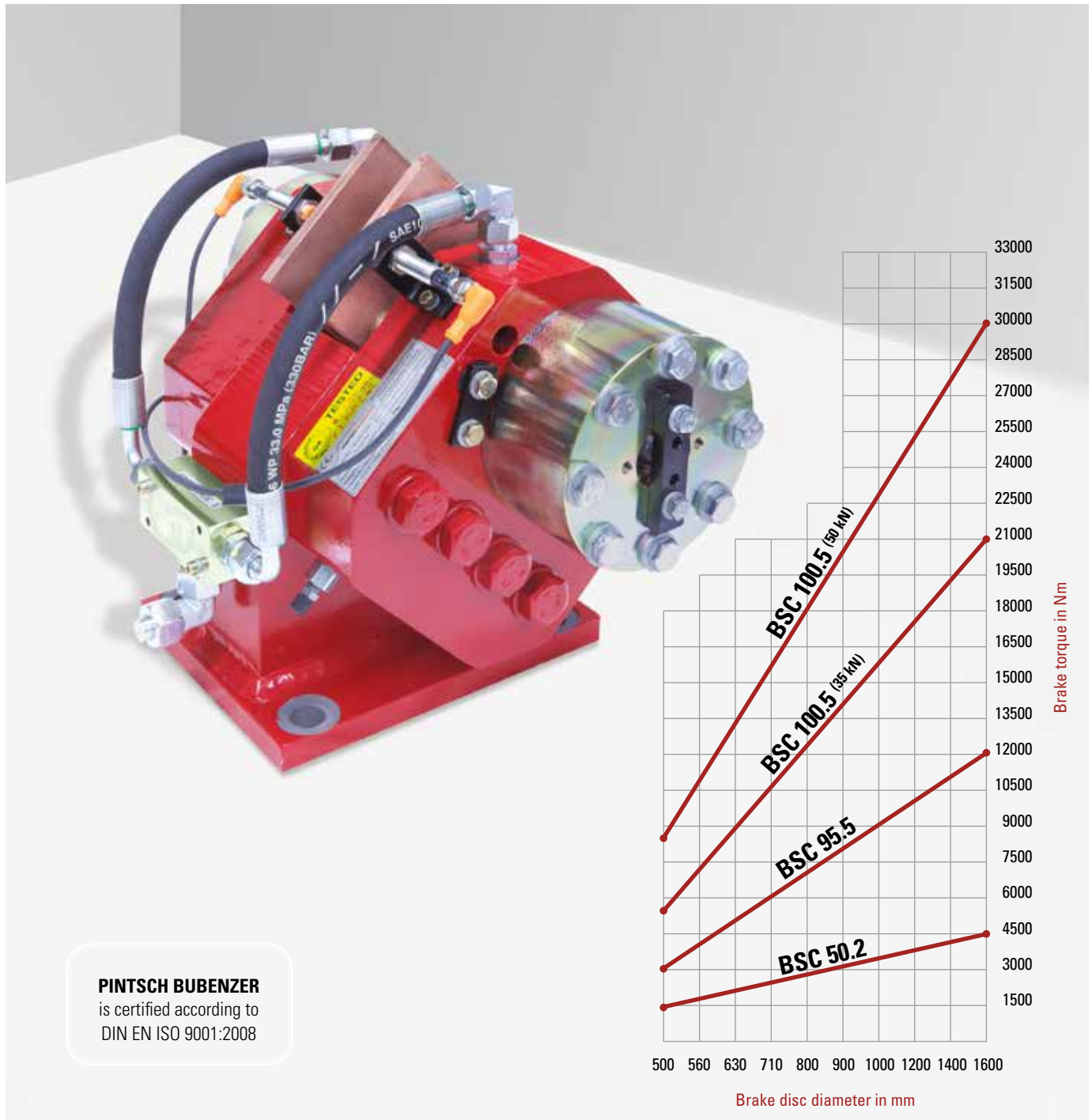

PINTSCH BUBENZER
is certified according to
DIN EN ISO 9001:2008

Reliable

High Performance

Robust Design

Compact

Description BSC



Main Features

- Two identical caliper halves, ready for operation, with spring packs set to nominal force
- Up to 1 mm air gap between brake pad and disc
- Easy, manual pad wear compensation
- Organic, non-asbestos linings

Options

- Limit switch release control
- Limit switch wear control
- Sintered linings
- Complete piped supports for one or more calipers
- Hydraulic power units
- Special seals for flameproof fluids
- Cleaning pads
- Brake discs

Applications

- The high capacity of these brakes makes them particularly suitable as service- or secondary emergency brakes e.g. on hoists, slewing drives and belt conveyors
- Other applications are in material handling, mechanical engineering and wind turbine industry, where high holding forces are required independent of the direction of rotation within limited space

Operating Restrictions

Brakes of this range are mechanically and hydraulically tested and are set to nominal force. This setting can only be changed by the manufacturer. Operating conditions other than described in this brochure require the manufacturer's approval and may influence the function of the caliper and its components



Please Note

We supply a detailed operating manual with every order. Nevertheless, we would point out that brakes are only as safe as the servicing and maintenance performed while they are in operation. The guarantee for the correct functioning of our brakes is only valid if the user adheres to the German DIN standard 15434 part 2 (drum and disc brakes, servicing and maintenance in operation), or to comparable standards in his own country.



PINTSCH BUBENZER Service

This includes the verification of the brake selection, if required. A detailed questionnaire is provided for this purpose. Installation and commissioning on-site by PINTSCH BUBENZER service engineers is possible. Drawings as DWG/ DXF files for your engineering department are available upon request.

Disc Brake BSC

Dimensions and technical data



Rev. 03-16

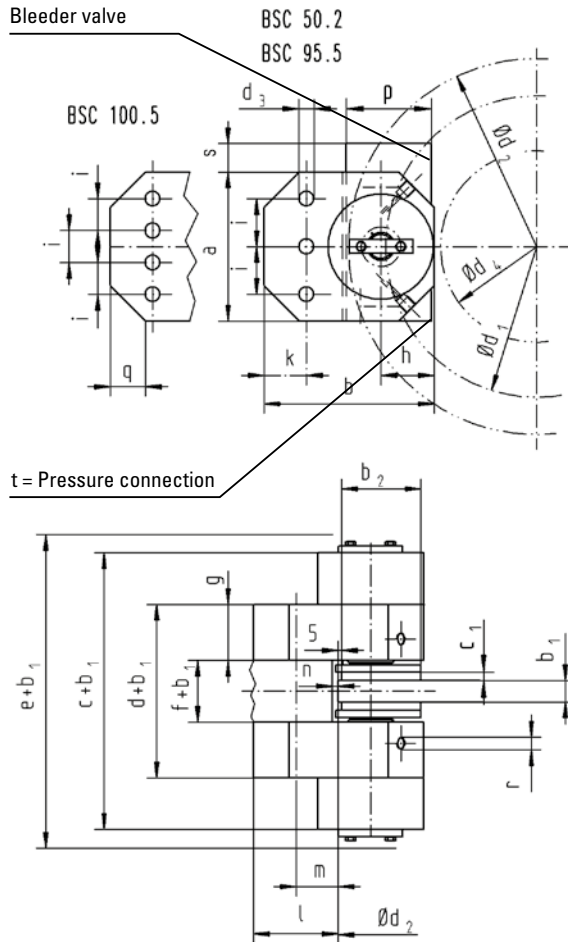

*) Average friction factor of standard material combination
All dimensions in mm. Alterations reserved without notice.

Brake torque M_{Br} in Nm = F_A (kN) x μ x d_1 (mm)

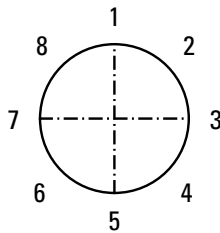

Please indicate required mounting position

Type BSC	50.2	95.5	100.5		
a	130	220	210		
b	128	213	240		
b ₂	63	112	112		
c	224	380	360		
c ₁	6	12	12		
d	108	137	215		
d ₃	14	21	22		
e	302	435	412		
f	38	57	57		
g	35	40	79		
h	42	75	75		
i	35	47,5	45		
k	24	32	60		
l	53	78	119		
m	29	46	59		
n	7	8	8		
p	70	120	120		
q	30x30°	25x45°	50x45°		
r	1/4"	3/8"	3/8"		
s	30	34	40		
t	Ø10	Ø12	Ø12		
Bolt	Ø	M12	M20	M20	
Bolt material		8.8	8.8	10.9	
Tighten. torque, Nm		86	410	560	
Data per caliper half	Contact force F_A kN	7	20	35	50
	Op. pressure bar	60	60	100	160
	Max. pressure bar	90	100	180	
	Release stroke mm	1	1	1	
	Oil volume l	0,002	0,004	0,005	
	Pad surface cm ²	73	195	195	
	Theor. friction μ^*	0,40	0,40	0,40	
Weight (kg)	12	30	40		

Brake disc data

	BSC 50.2	BSC 95.5	BSC 100.5
d ₁ =	d ₂ -70 mm	d ₂ -105 mm	d ₂ -105 mm
d ₄ =	d ₂ -170 mm	d ₂ -284 mm	d ₂ -260 mm

d₂ = Brake disc diameter in mm

d₁ = Friction diameter in mm

d₄ = Max. permissible drum or hub diameter in mm

b₁ = Disc thickness in mm (min. 30)

Disc Brake BSC

Hydraulic power unit for one or more calipers



Rev. 09-02

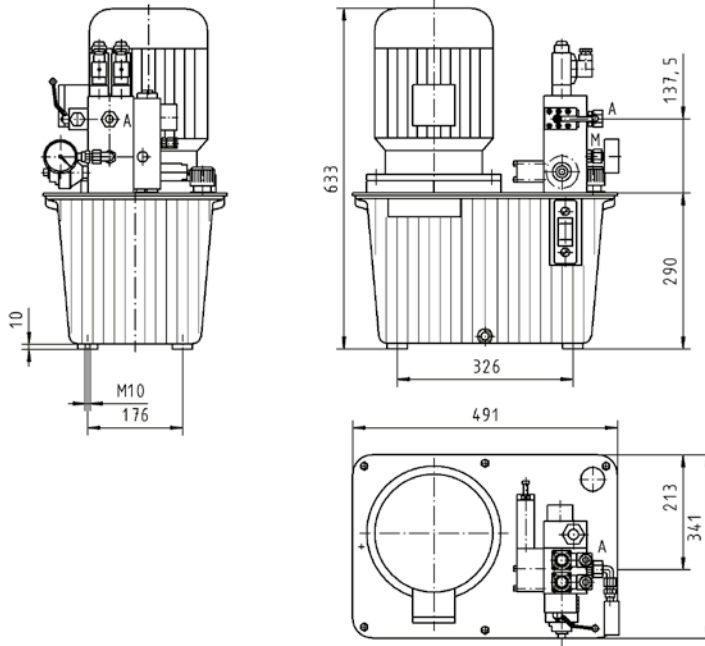

Example:	
Standard configuration up to 4 BSC 100.3	
Motor:	3 kW
Pump:	9 l/min
Pressure:	180 bar
Tank:	30 l

The flow diagram shows the general arrangement of the hydraulic power unit, including hand pump for emergency manual release of the brakes.

The two solenoid valves are connected in parallel (redundancy). After the nominal pressure is reached, the idler valve switches into idle running. The motor is continuously energized. Pressure switch, temperature switch, space heater and other accessories are available as options.

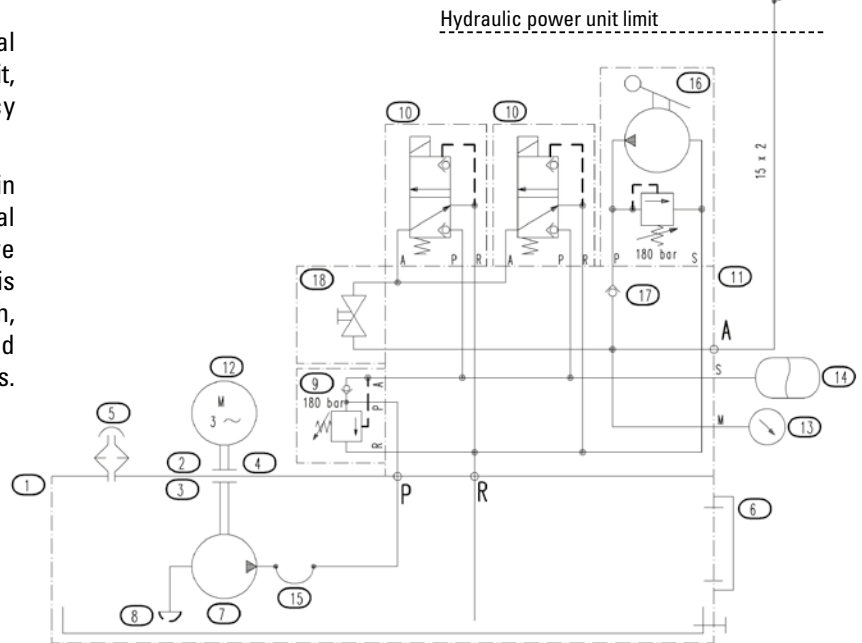

All dimensions in mm
Alterations reserved without notice



We supply a complete hydraulic and electric diagram according to the order specification with every order.

Hydraulic Caliper Disc Brakes BAC Series

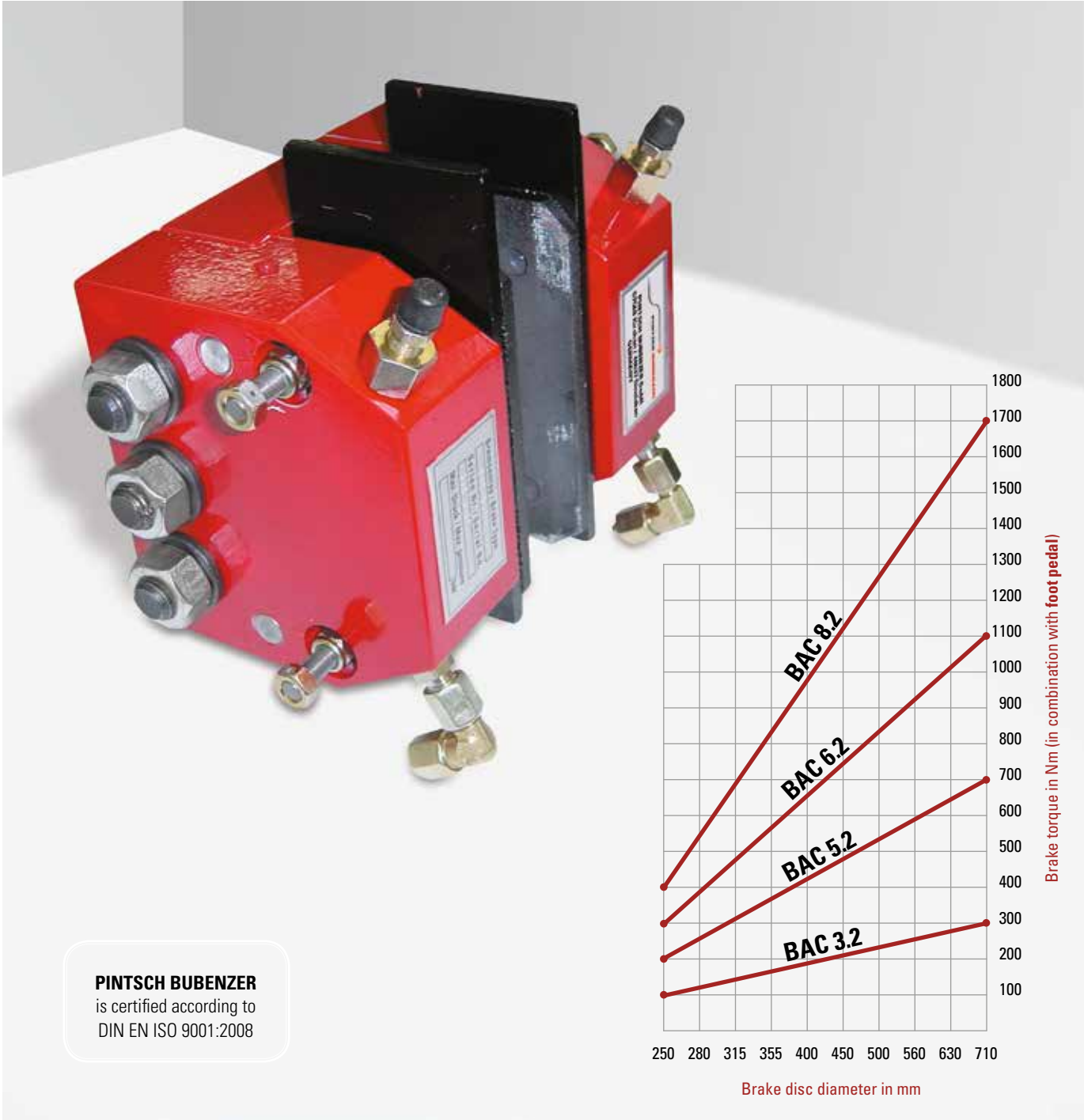

PINTSCH BUBENZER
is certified according to
DIN EN ISO 9001:2008



Direct-acting braking



High Performance



Robust Design



Compact

Description BAC



Main Features

- Brake hydraulic or pneumatic applied, spring released
- No failsafe function!**
- Adjustable retraction springs
- Automatic wear adjusting brake linings
- Organic, non-asbestos linings
- Operation by foot pedal or separate hydraulic power unit
- Air gap between brake pad and disc up to 2 mm per side

Options

- Limit switch release control
- Sintered linings
- Complete piped supports for one or more calipers
- Hydraulic power units
- Pneumatic power units
- Hydraulic foot pedals (see page 72)
- Brake discs
- Extended air gap more than 2 mm on request

Applications

Stopping and/or holding of fans, blowers, wind turbines, coilers, crane slewing and travel gears etc..



Please Note

We supply a detailed operating manual with every order. Nevertheless, we would point out that brakes are only as safe as the servicing and maintenance performed while they are in operation. The guarantee for the correct functioning of our brakes is only valid if the user adheres to the German DIN standard 15434 part 2 (drum and disc brakes, servicing and maintenance in operation), or to comparable standards in his own country.



PINTSCH BUBENZER Service

This includes the verification of the brake selection, if required. A detailed questionnaire is provided for this purpose. Installation and commissioning on-site by PINTSCH BUBENZER service engineers is possible. Drawings as DWG/DXF files for your engineering department are available upon request.

Disc Brake BAC

Dimensions and technical data



Rev. 03-16

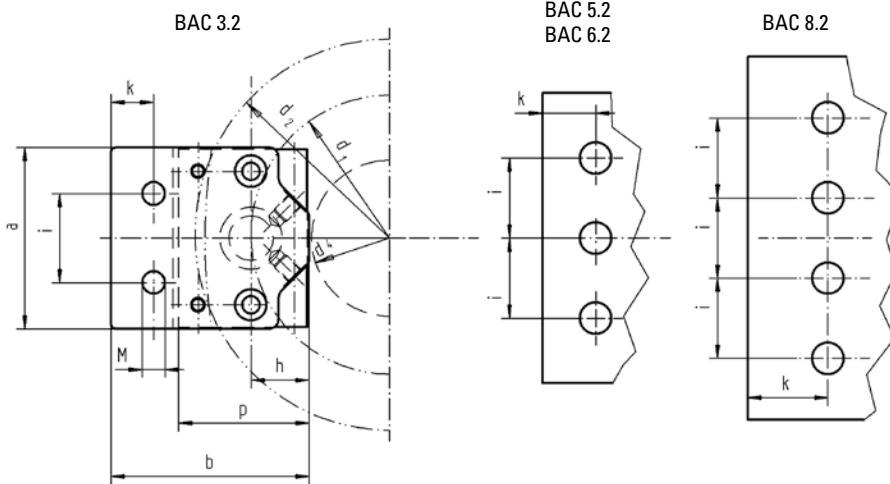

f_1 = Factor, see table
 f_2 = Factor, see table
 d_2 = Disc diameter in mm
 p_{vorh} = Existing operating pressure in bar

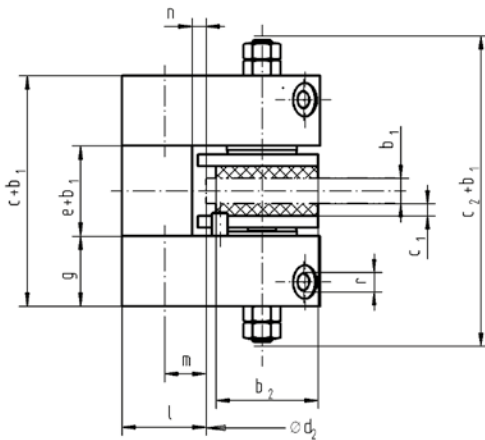

All dimensions in mm
 Alterations reserved without notice

Brake torque M_{Br} in Nm = $f_1 \times (d_2 - f_2) \times p_{vorh}$

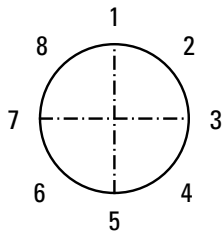

Please indicate required mounting position

Type BAC	3.2	5.2	6.2	8.2
a	102	130	163	204
b	100	120	141	182
b ₂	51	63	82	95
c	103	137	156	178
c ₁	6	6	8	8
c ₂	143	164	188	244
g	35	50	54	65
h	30	40	46	60
i	50	35	45	45
k	24	26	30	45
l	42	47	50	72
m	16	19	20	27
n	7	7	6	10
p	62	79	97	120
r	1/8"	1/8"	1/4"	3/8"
e	33	37	48	48
Bolt	ø M10	M12	M16	M16
Bolt material	10.9	10.9	10.9	10.9
Tighten. torque, Nm	69	120	295	295
Pad surface cm ²	46,5	74	118	168
Piston surface cm ²	9,5	19	33	50
Max. pressure bar	90	120	120	120
Max. stroke mm	1,6	2	2	2
Weight (kg)	8	10	20	35
Factor f_1	0,033	0,067	0,115	0,175
Factor f_2	60	70	90	100

Data per caliper half

Notes



A series of horizontal lines spanning the width of the page, providing a template for writing notes.

Hydraulic Caliper Disc Brakes SFR Series



PINTSCH BUBENZER
is certified according to
DIN EN ISO 9001:2008

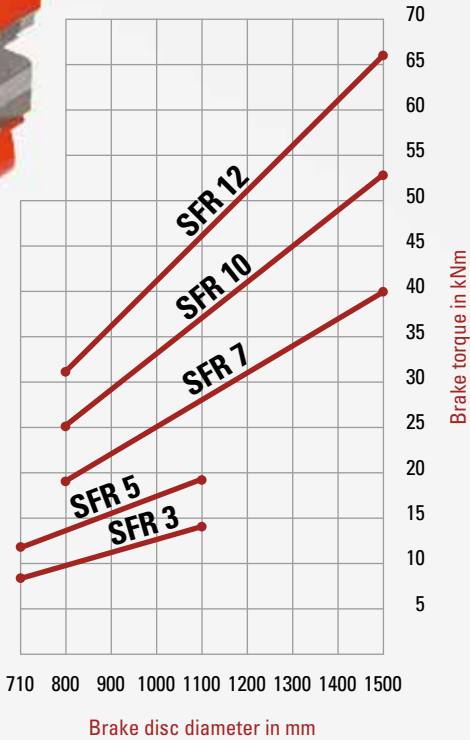



Reliable



High Performance



Robust Design



Easy Maintenance

Description SFR



Main Features

- **Monospring** caliper brake, ready to operate, with spring pack set to nominal force
- **Sintered linings**
- Limit switch release control
- Easy, manual pad wear compensation
- Horizontal compensation +/- 5 mm
- Support for direct gear box mounting

Options

- Limit switch wear control
- Hydraulic power units
- Brake discs and couplings
- Seals for special fluids
- **Sensors for remote monitoring** and diagnostic, like e.g. spring force-, temperature-, wear- and release gap monitoring
- CMB contact force measurement

Applications

- The high capacity of these brakes makes them particularly suitable as rotor brakes in wind turbines
- Other applications are possible in material handling, requiring power and compact design in either direction of rotation, e.g. hoisting applications and conveyor belts
- Use of the brakes for applications with high duty cycles should be specifically indicated during technical selection procedure

Operating Restrictions

- Brakes of this range are tested both mechanically and hydraulically and are set to nominal force. This setting can only be changed by the manufacturer. Operating conditions other than described in this brochure require the manufacturer's approval and may influence the function of the caliper and its components



Please Note

We supply a detailed operating manual with every order. Nevertheless, we would point out that brakes are only as safe as the servicing and maintenance performed while they are in operation. The guarantee for the correct functioning of our brakes is only valid if the user adheres to the German DIN standard 15434 part 2 (drum and disc brakes, servicing and maintenance in operation), or to comparable standards in his own country.



PINTSCH BUBENZER Service

This includes the verification of the brake selection, if required. A detailed questionnaire is provided for this purpose. Installation and commissioning on-site by PINTSCH BUBENZER service engineers is possible. Drawings as DWG/DXF files for your engineering department are available upon request.

Disc Brake SFR 3-5

Dimensions and technical data



Rev. 05-08

Brake is available also as „hydraulic applied“ version (SFRA, upon request)

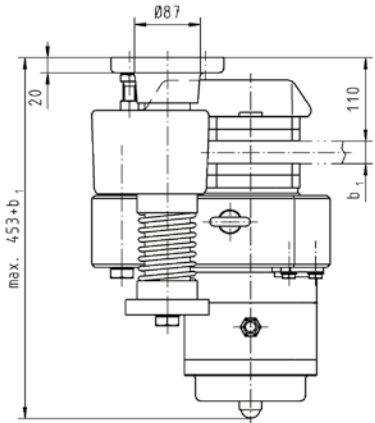
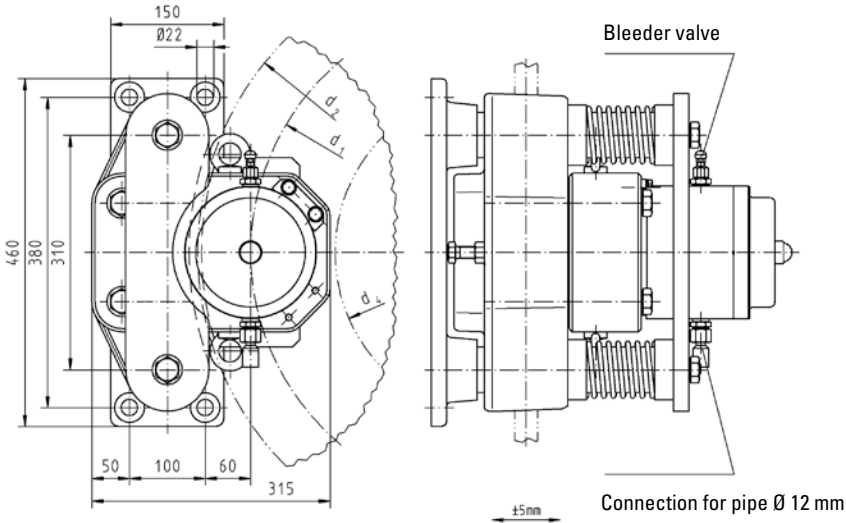

Horizontal compensation

*) Average friction factor of standard material combination

All dimensions in mm
Alterations reserved without notice

All dimensions in mm
Alterations reserved without notice

Brake torque M_{Br} in Nm = F_A (kN) x μ x d_1 (mm)

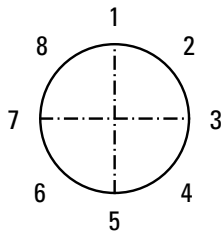

 Please indicate required mounting position

Type SFR		3	5
Contact force F_A	kN	35	50
Operating pressure	bar	55	80
Max. pressure	bar	135	135
Rel. stroke (per side)	mm	1	1
Oil volume	l	0.023	0.023
Pad surface (1 pad)	cm ²	300	300
Theor. friction	μ^*	0.4	0.4
Weight	kg	159	159
Bolt	Ø	M20	M20
Bolt material		10.9	10.9
Tighten. torque	Nm	560	560

Brake disc		
Brake disc Ø d_2	mm	710... 1100
Friction Ø d_1	mm	d2-140
Max. perm. Hub Ø d_4	mm	d2-360
Disc thickness b_1	mm	30... 40

Disc Brake SFR 7-12

Dimensions and technical data



Rev. 01-10

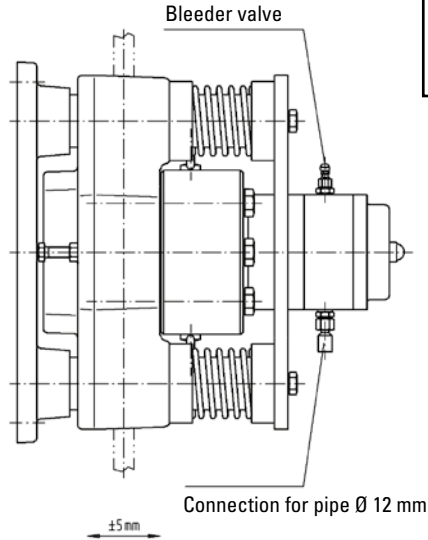
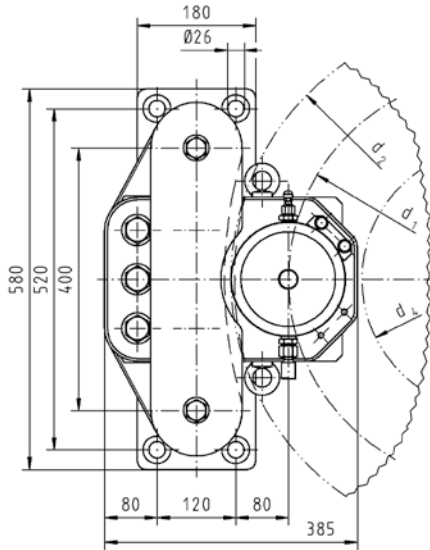

Brake is available also as „hydraulic applied“ version (SFRA, upon request)

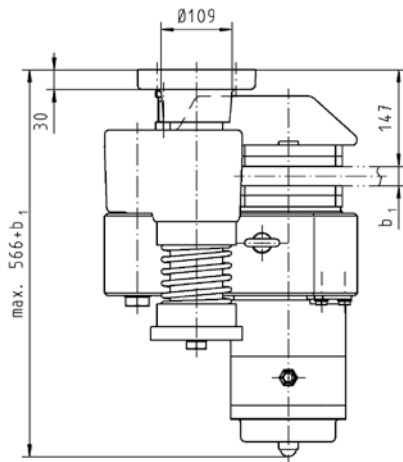

Horizontal compensation

*) Average friction factor of standard material combination

All dimensions in mm
Alterations reserved without notice

All dimensions in mm
Alterations reserved without notice

Brake torque M_{Br} in Nm = F_A (kN) x μ x d_1 (mm)

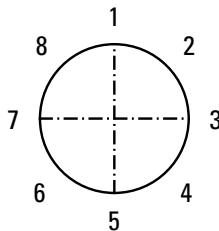

Please indicate required mounting position

Type SFR		7	10	12
Contact force F_A	kN	75	100	125
Operating pressure	bar	130	150	160
Max. pressure	bar	180	180	180
Rel. stroke (per side)	mm	1	1	1
Oil volume	l	0.023	0.023	0.023
Pad surface (1 pad)	cm ²	400	400	400
Theor. friction	μ^*	0.4	0.4	0.4
Weight	kg	279	279	279
Bolt	\emptyset	M24	M24	M24
Bolt material		10.9	10.9	10.9
Tighten. torque	Nm	960	960	1125

Brake disc		
Brake disc $\emptyset d_2$	mm	800... 1700
Friction $\emptyset d_1$	mm	d2-140
Max. perm. Hub $\emptyset d_4$	mm	d2-395
Disc thickness b_1	mm	30... 40

Disc Brake SFR

Hydraulic power unit, example (please also see page B10)



Rev. 11-03

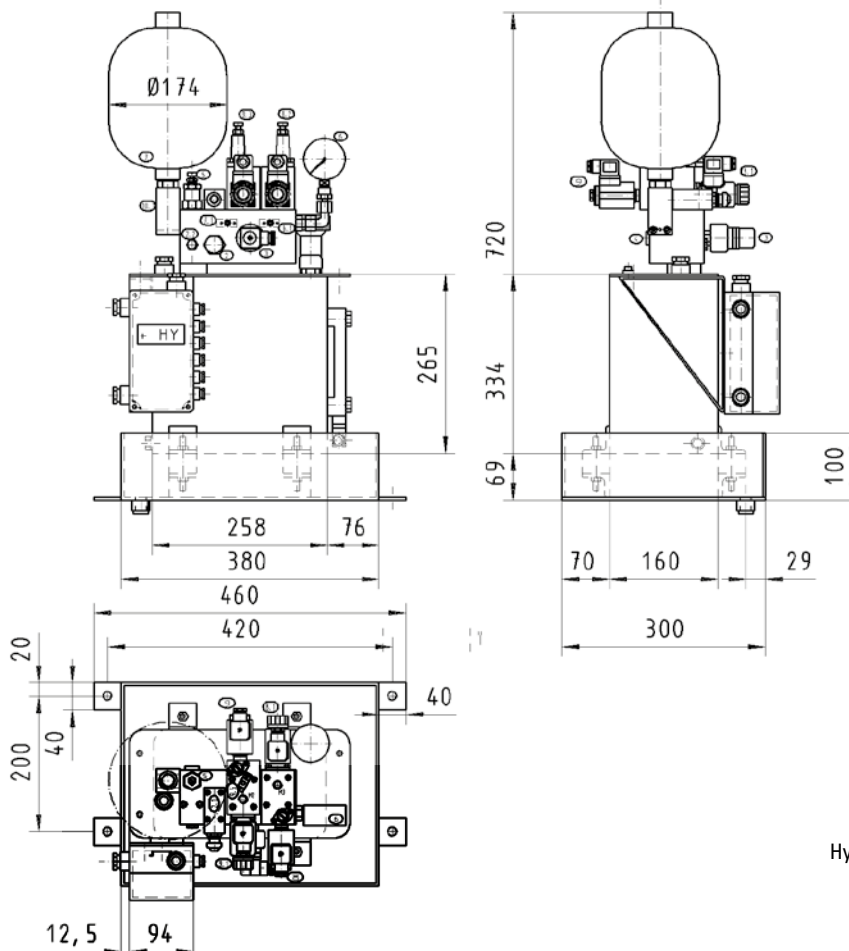

Example:	
Standard configuration up to 2 St. SFR (Rotor) up to 2 St. BAC (Yaw)	
Motor:	0.25 kW
Accumulator:	2.8 l
Pressure:	160 bar
Tank:	10 l

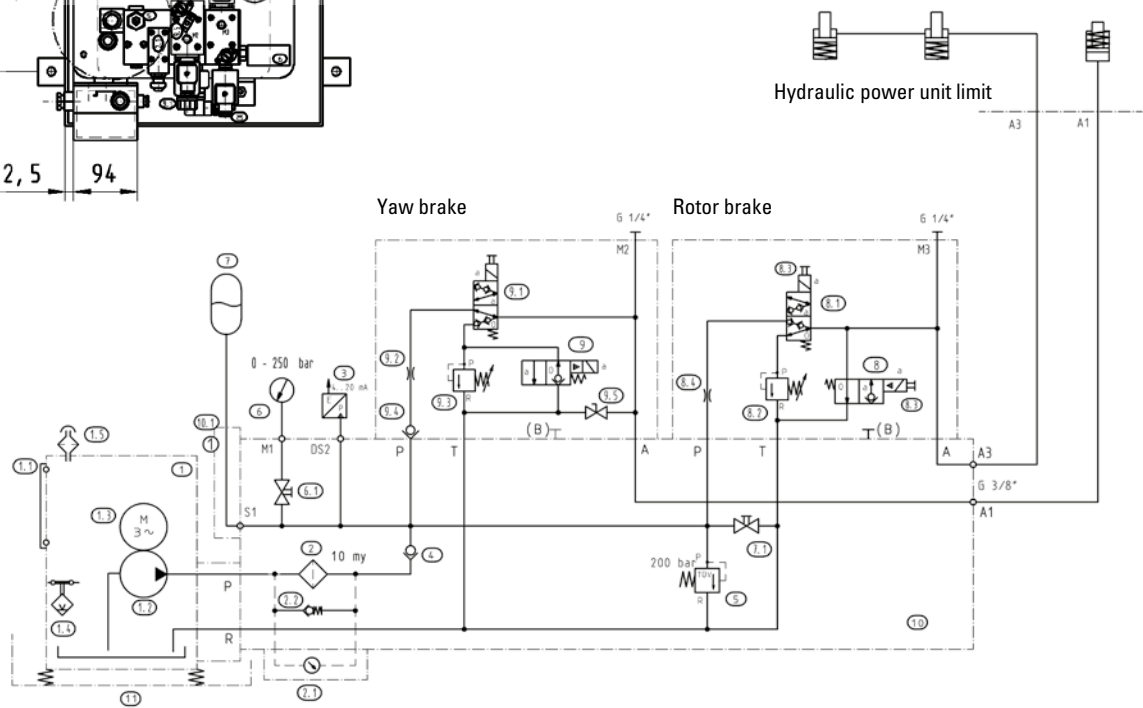

All dimensions in mm
Alterations reserved without notice

Spring Set Brakes SFB Series



PINTSCH BUBENZER
is certified according to
DIN EN ISO 9001:2008



Reliable



High Performance



Robust



Easy Maintenance



Compact



Tried and Trusted

Description SFB Series



Main Features

Spring applied safety brake
Electromechanically released
Protection-class IP67
Double wear reserve by single air gap adjustment
High work capacity
High wear resistance because of high abrasion resistance
Functional without cover
Emergency release screws

Applications

Gantry, trolley and hoisting applications
Electrical drives for ship winches and deck machinery
Jack up systems at offshore systems
Dynamic and static use at general industrial applications

Certificates

ABS, DNV, LR, GL, RMROS, BV

Options

Special brake torque:
Lower brake torque = type SFB
Higher brake torque = type SFB-SH
Holding brake torques available on request
Micro- or proximity switches:
• Monitoring the function on/off
• Maximum air gap (wear-monitoring)
Lateral junction box
Tacho preparation with all mounting parts
Cover bore
Shaft sealing
Special voltage
Anti condensation heater
Radial cable outlet
Special flange

Electrical equipment

One-way, bridge and switching rectifier
Protective element
Brake control unit = BCU 2001
Brake control and monitoring system = BCMS-4



Please Note

We supply a detailed operating manual with every order. Nevertheless, we would point out that brakes are only as safe as the servicing and maintenance performed while they are in operation. The guarantee for the correct functioning of our brakes is only valid if the user adheres to the German DIN standard 15434 part 2 (drum and disc brakes, servicing and maintenance in operation), or to comparable standards in his own country.



PINTSCH BUBENZER Service

This includes the verification of the brake selection, if required. A detailed questionnaire is provided for this purpose. Installation and commissioning on-site by PINTSCH BUBENZER service engineers is possible. Drawings as DWG/DXF files for your engineering department are available upon request.

Spring Set Brake SFB

Electromagnetic Two Disc, Spring Set Brake



Rev. 05-08

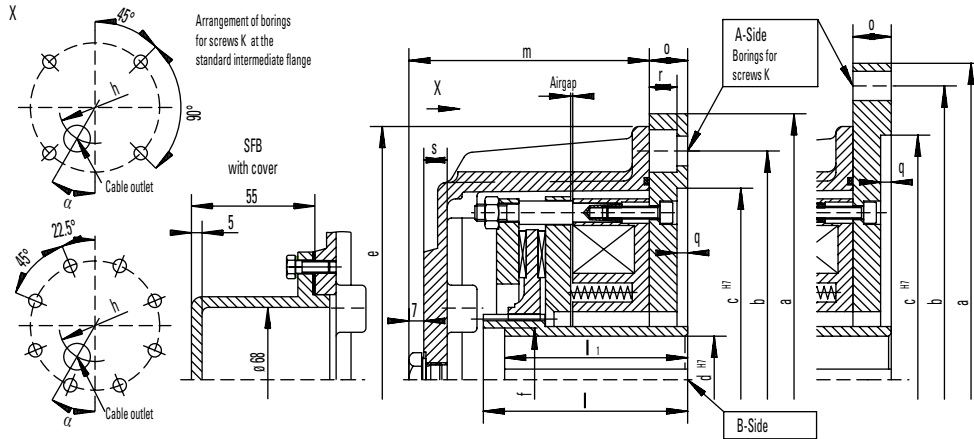

Keyways for keys acc. to DIN6885 Bl.1, width accuracy P9. Protection IP67

Alterations reserved without notice

Brake size			SFB 6.3	SFB 10	SFB 16	SFB 25	SFB 40	SFB 63	SFB 100	SFB 160	SFB 250			
Brake torque M2 dynamic acc. to DIN VDE 0580	Nm		63	100	160	250	400	630	1000	1600	2500			
			54	80	130	210	330	520	830	1300	2100			
			45	63	100	180	260	400	660	1050	1650			
Mass moment of inertia	kgm ²	0.0017	0.0037	0.0048	0.0068	0.0175	0.036	0.050	0.128	0.140				
Mass (weight)	kg	19	28	42	55	74	106	168	242	306				
max. speed	min ⁻¹	6000	6000	6000	5500	4700	4000	3600	3200	2800				
Coil b. 20° C	Nominal voltage	V DC	110	110	110	110	110	110	110	110	110			
	Nominal power	W	99	128	158	196	220	307	344	435	495			
	Nominal current	A	0.90	1.16	1.44	1.78	2.0	2.79	3.13	3.95	4.50			
Air gap, brake OFF		min. mm	0.3	0.3	0.3	0.4	0.4	0.4	0.6	0.4	0.4			
		max. mm	0.9	1.2	1.2	1.3	1.4	1.8	1.8	2.3	2.5			
Diameter mm	B-Side	d Rough boring	26	26	36	36	36	36	36	46	46			
		d ^{H7} Preferential boring		28	28	38	38	48	60	60	65	65		
				32	32	42	42	55	65	65	70	70		
				38	38	48	48	60	75	75	75	75		
						55	55				80	80		
	d ^{H7} maximal	40	40	55	55	60	75	75	110	110				
Length mm	e	238	260	280	318	400	440	446	540	556				
	f						95	95	128	128				
	h	150	180	202	214	244	292	330	394	440				
	l	96	96	117	117	142	148	148	191	191				
	l ¹	96	96	117	117	142	142	142	171	171				
	m	115	118	137	143	169	171	183	211	232				
	s	11	11	11	12	14	15	15	15	15				
A	α°	15	15	30	22.5	30	30	30	30	45				
Suitable standard Intermediate flange			A250	A300	A300-1	A350	A400-1	A450-1	A450-1	A550-1	A660			
			A300	A350	A350	A400	A450	A550	A550	A660	A800			
					A400	A450	A550	A660	A660	A800				
					A450									
Dimensions of standard intermediate flanges														
Standard intermediate flange			A250	A300	A300-1	A350	A400	A400-1	A450	A450-1	A550	A550-1	A660	A800
Diameter mm	a	250	300	300	350	400	400	450	450	550	550	660	800	
	b	215	265	265	300	350	350	400	400	500	500	600	740	
	c ^{H7}	180	230	230	250	300	300	350	350	450	450	550	680	
Length mm	o	18	18	18	20	22	22	24	24	24	24	30	30	
	q	5	5	5	6	6	6	6	6	6	6	7	7	
	r	13		13			17.5		17.5		17.5			
	Screws k	4xM12	4xM12	4xM12	4xM16	4xM16	4xM16	4xM12	8xM16	8xM16	8xM16	8xM20	8xM20	

Spring Set Brake SFB

Electromagnetic Two Disc, Spring Set Brake



Rev. 05-08

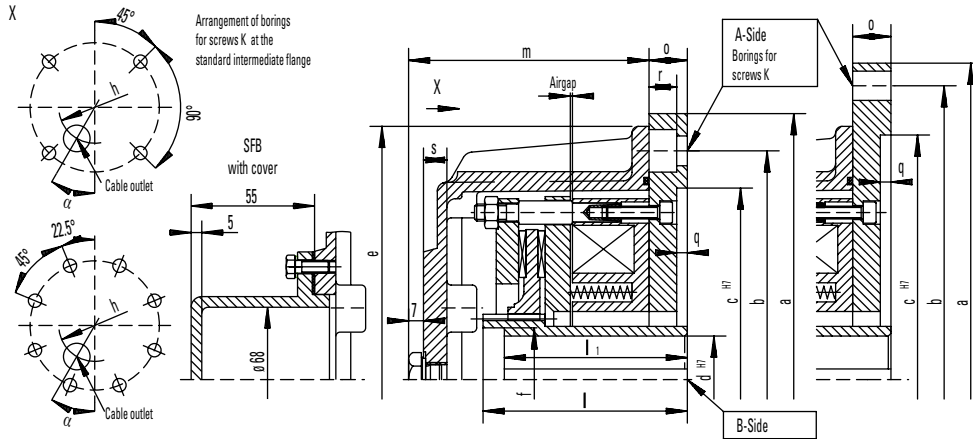

Brake size		SFB 400	SFB 630	SFB 1000	
Brake torque M2 dynamic acc. to DIN VDE 0580	Nm	4000	6300	10000	
		3350	5250	8500	
		2650	4200	7000	
Mass moment of inertia	kgm ²	0.325	0.375	1.007	
Mass (weight)	kg	357	500	750	
max. speed	min ⁻¹	2500	2200	2000	
Coil c b. 20°C	Nominal voltage	V DC	110	110	110
	Nominal power	W	553	671	980
	Nominal current	A	5.03	6.10	8.91
Air gap, brake OFF		min. mm	0.4	0.7	0.7
		max. mm	2.5	2.8	3.1
Diameter mm	B-Side	d Rough boring	46	58	68
		d ^{H7} Preferential boring	65	100	125
			70		
			75		
			80		
			90		
d ^{H7} maximal	110	125	140		
Length mm	e	660	700	795	
	f	128	140	155	
	h	520	570	620	
	l	191	237	282	
	l ¹	171	210	255	
	m	272	310	360	
	s	15	15	15	
A	α°	30	30	30	
Suitable standard intermediate flange		A660-1	A800	A800-1	
		A800			
		Dimensions of standard intermediate flange			
Standard intermediate flange		A660-1	A800	A800-1	
Diameter mm	a	660	800	800	
	b	600	740	740	
	c ^{H7}	550	680	680	
Length mm	o	30	30	30	
	q	7	7	7	
	r	21.5		21.5	
	Screws k	8xM20	8xM20	8xM20	

Keyways for keys acc. to DIN6885 Bl.1, width accuracy P9. Protection IP67

Alterations reserved without notice

Spring Set Brake SFB-SH

Electromagnetic Two Disc, Spring Set Brake
Increased brake torque



Rev. 05-08

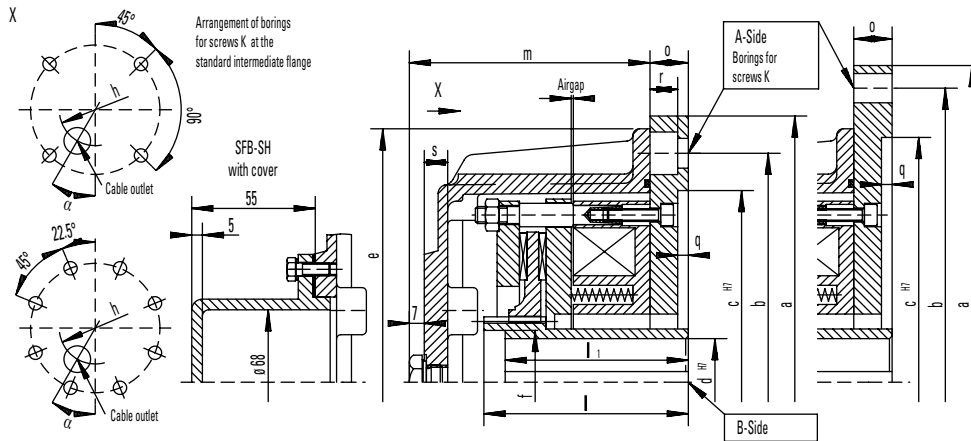

Keyways for keys acc. to DIN6885 Bl.1, width accuracy P9. Protection IP67

Alterations reserved without notice

Brake size			SFB 6.3-SH	SFB 10-SH	SFB 16-SH	SFB 25-SH	SFB 40-SH	SFB 63-SH	SFB 100-SH	SFB 160-SH	SFB 250-SH			
Brake torque M2 dynamic acc. to DIN VDE 0580	Nm		80	130	210	350	550	800	1300	2100	3300			
			75	120	190	310	490	750	1200	1900	3000			
			69	110	180	275	440	690	1100	1750	2750			
Mass moment of inertia	kgm ²	0.0017	0.0037	0.0048	0.0068	0.0175	0.036	0.050	0.128	0.140				
Mass (weight)	kg	19	28	42	55	74	106	168	242	306				
max. speed	min ⁻¹	6000	6000	6000	5500	4700	4000	3600	3200	2800				
Coil b. 20°C	Nominal voltage	V DC	110	110	110	110	110	110	110	110	110			
	Nominal power	W	99	128	158	196	220	307	344	435	495			
	Nominal current	A	0.90	1.16	1.44	1.78	2.0	2.79	3.13	3.95	4.50			
Air gap, brake OFF		min. mm	0.3	0.3	0.3	0.4	0.4	0.4	0.6	0.4	0.4			
		max. mm	0.9	1.2	1.2	1.3	1.4	1.8	1.8	2.3	2.5			
Diameter mm	B-Side	d Rough boring	26	26	36	36	36	36	36	46	46			
		d ^{H7} Preferential boring		28	28	38	38	48	60	60	65	65		
				32	32	42	42	55	65	65	70	70		
				38	38	48	48	60	75	75	75	75		
						55	55				80	80		
	d ^{H7} maximal	40	40	55	55	60	75	75	110	110				
Length mm	e		238	260	280	318	400	440	446	540	556			
	f							95	95	128	128			
	h		150	180	202	214	244	292	330	394	440			
	l		96	96	117	117	142	148	148	191	191			
	l ¹		96	96	117	117	142	142	142	171	171			
	m		115	118	137	143	169	171	183	211	232			
	s		11	11	11	12	14	15	15	15	15			
A	α°		15	15	30	22.5	30	30	30	30	45			
Suitable standard intermediate flange			A250	A300	A300-1	A350	A400-1	A450-1	A450-1	A550-1	A660			
			A300	A350	A350	A400	A450	A550	A550	A660	A800			
					A400	A450	A550	A660	A660	A800				
					A450									
Dimensions of standard intermediate flange														
Standard intermediate flange			A250	A300	A300-1	A350	A400	A400-1	A450	A450-1	A550	A550-1	A660	A800
Diameter mm	a		250	300	300	350	400	400	450	450	550	550	660	800
	b		215	265	265	300	350	350	400	400	500	500	600	740
	c ^{H7}		180	230	230	250	300	300	350	350	450	450	550	680
Length mm	o		18	18	18	20	22	22	24	24	24	24	30	30
	q		5	5	5	6	6	6	6	6	6	6	7	7
	r		13		13			17.5		17.5		17.5		
	Screws k		4xM12	4xM12	4xM12	4xM16	4xM16	4xM16	8xM16	8xM16	8xM16	8xM16	8xM20	8xM20

Spring Set Brake SFB-SH

Electromagnetic Two Disc, Spring Set Brake
Increased brake torque



Rev. 05-08

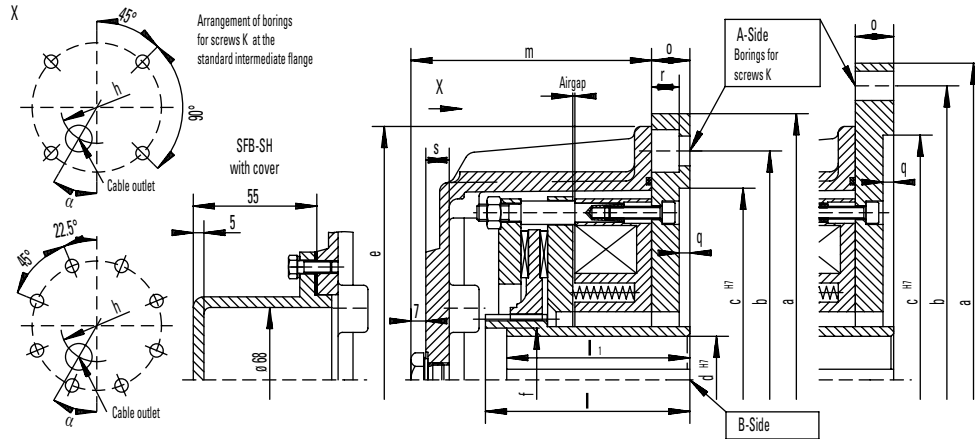

Brake size		SFB 400-SH	SFB 630-SH	SFB 1000-SH	
Brake torque M2 dynamic acc. to DIN VDE 0580	Nm	5200	8000	13000	
		4800	7500		
		4400	6900		
Mass moment of inertia	kgm ²	0.325	0.375	1.007	
Mass (weight)	kg	357	500	750	
max. speed	min ⁻¹	2500	2200	2000	
Coil b. 20° C	Nominal voltage	V DC	110	110	110
	Nominal power	W	553	671	980
	Nominal current	A	5.03	6.10	8.91
Air gap, brake OFF		min. mm	0.4	0.7	0.7
		max. mm	2.5	2.8	3.1
Diameter mm	B-Side	d Rough boring	46	58	68
		d ^{H7} Preferential boring	65	100	125
			70		
			75		
			80		
			90		
d ^{H7} maximal	110	125	140		
Length mm	e	660	700	795	
	f	128	140	155	
	h	520	570	620	
	l	191	237	282	
	l ¹	171	210	255	
	m	272	310	360	
	s	15	15	15	
∠	α°	30	30	30	
Suitable standard intermediate flange		A660-1	A800	A800-1	
		A800			
		Dimensions of standard intermediate flange			
Standard intermediate flange		A660-1	A800	A800-1	
Diameter mm	a	660	800	800	
	b	600	740	740	
	c ^{H7}	550	680	680	
Length mm	o	30	30	30	
	q	7	7	7	
	r	21.5		21.5	
	Screws k	8xM20	8xM20	8xM20	

Keyways for keys acc. to DIN6885 Bl.1,
width accuracy P9. Protection IP67

Alterations reserved without notice

Spring Set Brake KFB



PINTSCH BUBENZER
is certified according to
DIN EN ISO 9001:2008



Reliable



High Performance



Robust



Easy Maintenance



Compact



Tried and Trusted

Description KFB



Main Features

■	Spring applied safety brake
■	Electromechanically released
■	Protection-class IP67 – seawater protected
■	High wear reserve by multiple air gap adjustment
■	Small construction at high work capacity
■	High availability caused by high durability
■	Functional without cover
■	Emergency release screws

Applications

■	Gantry, trolley and hoisting application
■	Dynamic and static use at general industrial applications
■	General engineering
■	Steel mills
■	Wind energy systems
■	Coal mining

Certificates

■	ABS, ATEX
---	-----------

Options

■	Special brake torque
■	Handlever
■	Micro or proximity switch: <ul style="list-style-type: none">• Monitoring the function on/off• Maximum air gap (wear-monitoring)
■	Lateral junction box
■	Tacho preparation with all mounting parts
■	Cover bore
■	Shaft sealing
■	Special voltage
■	Anti condensation heater
■	Radial cable outlet
■	Special flange

Electrical equipment

■	One-way, bridge and switching rectifier
■	Protective element
■	Brake control unit = BCU 2001
■	Brake control and monitoring system = BCMS-4



Please Note

We supply a detailed operating manual with every order. Nevertheless, we would point out that brakes are only as safe as the servicing and maintenance performed while they are in operation. The guarantee for the correct functioning of our brakes is only valid if the user adheres to the German DIN standard 15434 part 2 (drum and disc brakes, servicing and maintenance in operation), or to comparable standards in his own country.



PINTSCH BUBENZER Service

This includes the verification of the brake selection, if required. A detailed questionnaire is provided for this purpose. Installation and commissioning on-site by PINTSCH BUBENZER service engineers is possible. Drawings as DWG/DXF files for your engineering department are available upon request.

Spring Set Brake KFB

Electromagnetic Two Disc, Spring Set Brake



Rev. 10-09

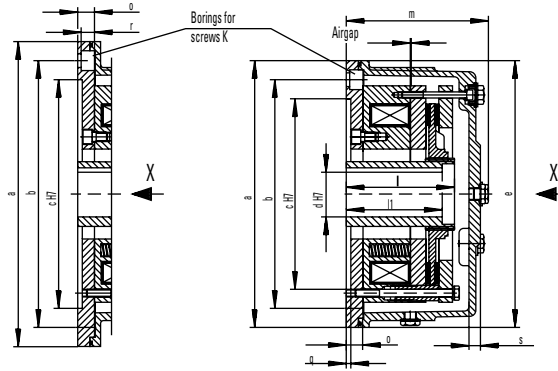
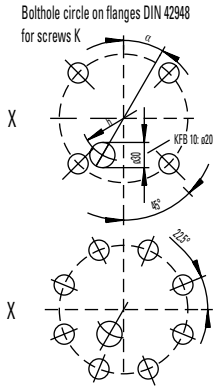

* The larger dimension belongs to the larger assigned brake

Alterations reserved without notice

Brake size		KFB 5	KFB 10	KFB 16	KFB 25	KFB 30	KFB 40	KFB 63	KFB 100	KFB 160
Brake torque M2 dynamic acc. to DIN VDE 0580 Nm		50	100	160	250	300	400	630	1000	1600
Mass moment of inertia kgm ²		0.0010	0.0017	0.0037	0.0048	0.0055	0.0068	0.0175	0.036	0.050
Mass (weight) kg		13	19	28	42	50	55	74	106	168
max. speed min ⁻¹		6000	6000	6000	6000	6000	5500	4700	4000	3600
Coil b. 20°C	Nominal voltage V DC	110	110	110	110	110	110	110	110	110
	Nominal power W	79	93	128	158	133	196	220	307	344
	Nominal current A	0.72	0.84	1.16	1.44	1.2	1.78	2.0	2.79	3.13
Air gap, OFF										
		norm. mm	0.3	0.3	0.3	0.3	0.3	0.4	0.4	0.4
		max. mm	0.8	1.0	1.0	1.2	0.8	1.2	1.3	1.6
Diameter mm	B-Side	d pilot bore	8	26	26	36	26	36	36	36
		d ^{H7} preferential bore	15	28	28	38	32	38	48	60
			20	32	32	42	38	42	55	65
			25	38	38	48	42	48	60	75
					55	45	55			
Length mm	e	160/200	200/250	253/303	300/350	250/300	303/350	350/400	400/450	450/550
	f									
	h	93	106	144	194	144	194	214	264	314
	l	110	110	96	117	137	117	142	148	155
	l ¹	110	110	96	117	137	117	142	142	142
	m	145	154	141	165	175	175	187	196	218
	s	13	15	15	15	15	15	15	15	17
A	α °	22.5	30	30	30	67.5	30	30	30	30
Suitable standards flanges		A160	A200	A250	A300	A250	A300	A350	A400	A450
		A200	A250	A300	A350	A300	A350	A400	A450	A550
		Dimensions of standards flanges								
Size of standards flanges		A160	A200	A250	A300	A350	A400	A450	A550	
Diameter mm	a	160	200	250	300	350	400	450	550	
	b	130	165	215	265	300	350	400	500	
	c ^{H7}	110	130	180	230	250	300	350	450	
Length mm	o	18	18	18/20*	20/22*	22	22/24*	24/29*	24/29*	
	q	5	5	5	5	6	6	6	6	
	r	11	11	13	13	17.5	17.5	17.5	17.5	
	k	4xM8	4xM10	4xM12	4xM12	4xM16	4xM16	8xM16	8xM16	

Brake rectifier
FWR



Brake rectifier
HWR



Protective element
PE-400/150/5



Brake rectifier
BGL+EGL



Switching rectifier
SGL

PINTSCH BUBENZER
is certified according to
DIN EN ISO 9001:2008



Reliable



High Performance



Robust



Easy Maintenance



Compact



Tried and Trusted

Description Accessories



Main Features

- EMC compatibility
- Top-hat rail mounted
- Combinable with Brake Control Unit BCU2001
- Integrated protective element
- Integrated spark quench element

Specific Features for the rectifiers BGL and EGL

- Prepared for switching AC and DC circuits simultaneously
- Installation in cabinet

Specific Features for the protective element PE 400/150/5

- To be connected parallel to the output of the rectifiers BGL, EGL and SGL to increase the interruption capacity

Specific Features for the rectifiers FWR and HWR

- Prepared for switching AC and DC circuits simultaneously
- Installation in junction box

Specific Features of the switching rectifier SGL

- Prepared for switching AC and DC circuits simultaneously
- Switches from bridge rectification to half-wave rectification
- Four time settings 0,5 s, 1 s, 1,5 s, 2 s adjustable
- Applying brakes at elevated temperatures
- Accelerated brake release (Overexcitation with AC power supply voltage = 2 x DC coil voltage)
- Accelerated brake effect (Standard excitation with AC power supply voltage = DC coil voltage)



Please Note

We supply a detailed operating manual with every order. Nevertheless, we would point out that brakes are only as safe as the servicing and maintenance performed while they are in operation. The guarantee for the correct functioning of our brakes is only valid if the user adheres to the German DIN standard 15434 part 2 (drum and disc brakes, servicing and maintenance in operation), or to comparable standards in his own country.



PINTSCH BUBENZER Service

This includes the verification of the brake selection, if required. A detailed questionnaire is provided for this purpose. Installation and commissioning on-site by PINTSCH BUBENZER service engineers is possible. Drawings as DWG/DXF files for your engineering department are available upon request.

BGL-PE400/150/3 - EGL-PE400/150/5

Principal circuit diagram



Rev. 03-09

Bridge rectification with module BGL

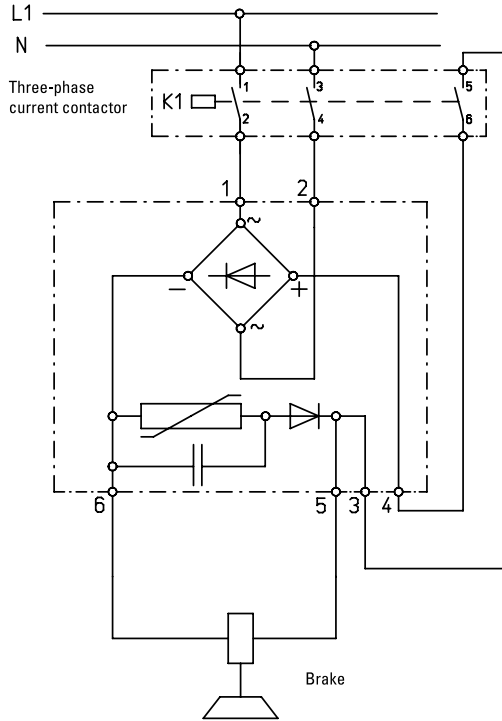

Half-wave rectification with module EGL

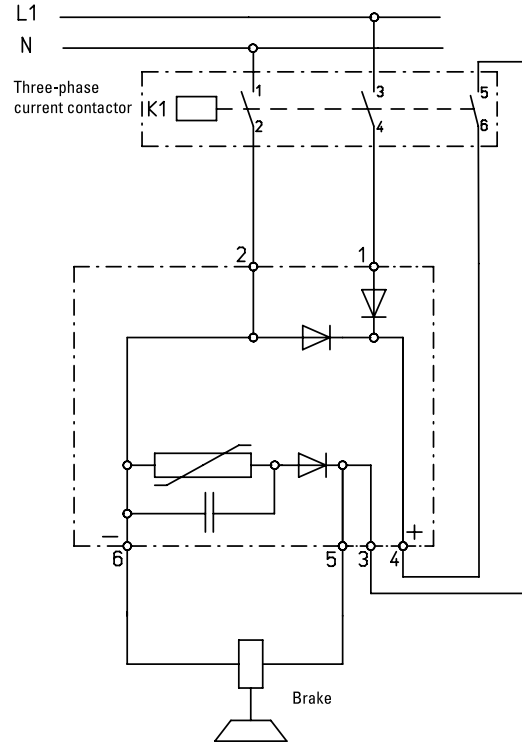

Technical data

Brake rectifier BGL-PE400/150/3

AC line voltage:	AC 460V; 50/60 Hz
Permissible rated coil voltages:	DC 24V...390V
Maximum brake current:	2,5A
Maximum continuous output of the internal protective circuit:	3W
Disconnection peak at maximum coil current:	≤450V
Ambient temperature:	-40° C ... +50° C
Protection class:	IP 20

Brake rectifier EGL-PE400/150/5

AC line voltage:	AC 460V; 50/60 Hz
Permissible rated coil voltages:	DC 24V...220V
Maximum brake current:	5A
Maximum continuous output of the internal protective circuit:	5W
Disconnection peak at maximum coil current:	≤450V
Ambient temperature:	-40° C ... +50° C
Protection class:	IP 20

Full wave rectifier FWR-PE400/150/3

Principal circuit diagram



Rev. 10-10

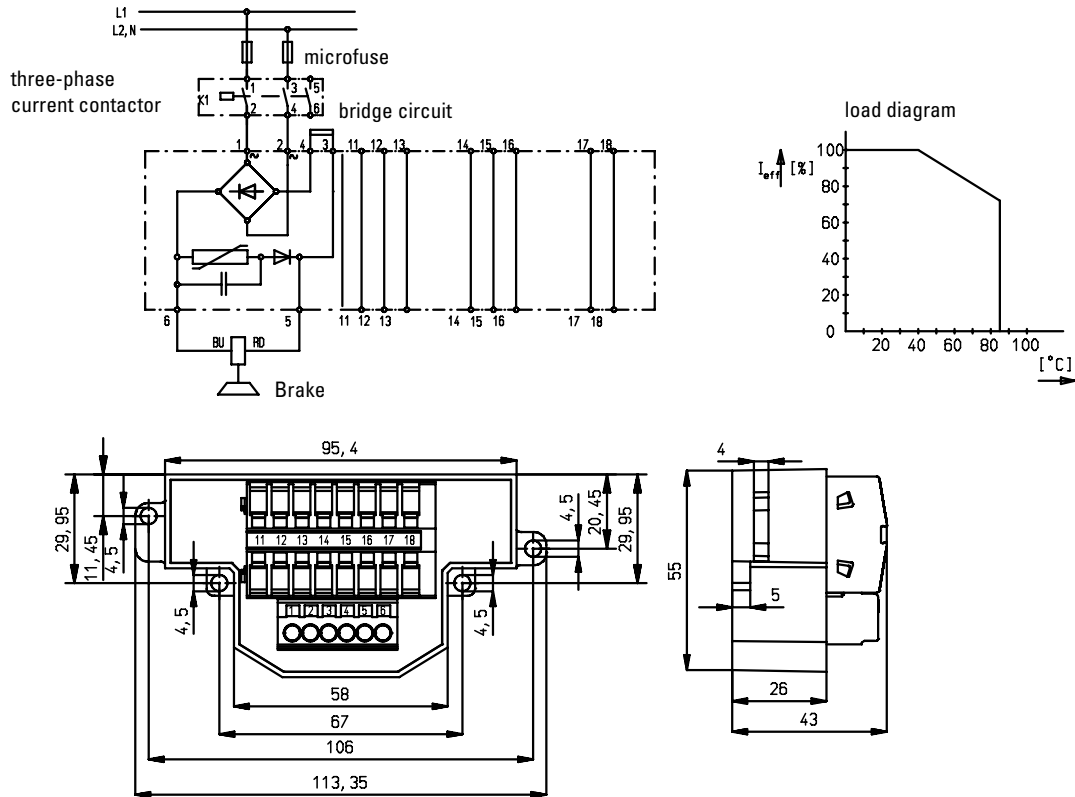

Technical data

Coil voltage of the connected brake	DC 24V ... 390V
Max. voltage of supplying alternating current network	AC 460V - 50/60 Hz
Max. Output current I_{eff} at $T_A = < 50^\circ\text{C}$	2,5 A
Max. Output current I_{eff} at max. T_A 85°C	1,8 A
Protection fuse in the AC input voltage line to the rectifier (In the selection of fuse is permissible on the $I^2 t$ limit load integral to eight)	FF 4A microfuse switching capacity H
Permitted limit integral $I^2 t$	700A ² s ($t < 10\text{ms}$)
Max. energy absorption of a shut-off	150 J
Max. continuous power of the internal protective circuit (average value)	3W
Shut-off peak at max. coil current	< 450V
Ambiente temperature T_A	$-40^\circ\text{C} \dots +85^\circ\text{C}$
Permissible cross section of connection wire	0,2 ... 2,5 mm AWG 24 ... 14
Weight	0,3 kg
Protection class	IP 65 components seal / IP20 terminals
Mark of conformity	CE / RoHS conform

Half wave rectifier HWR-PE400/150/5

Principal circuit diagram



Rev. 10-10

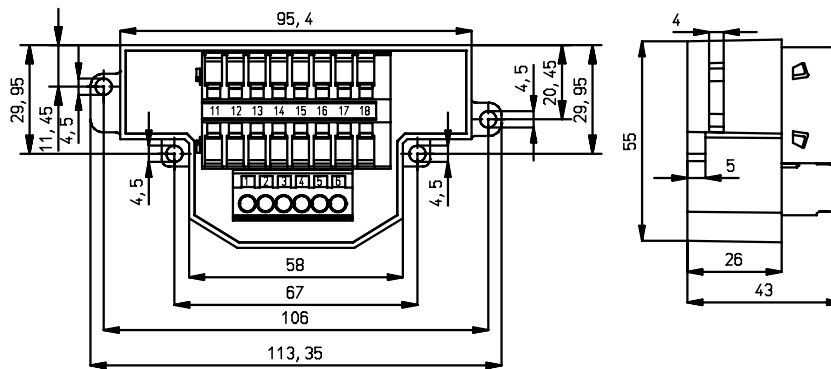
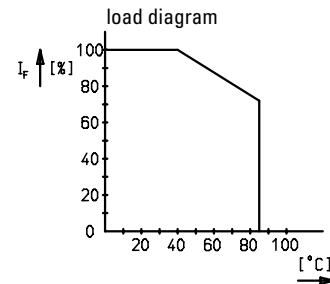
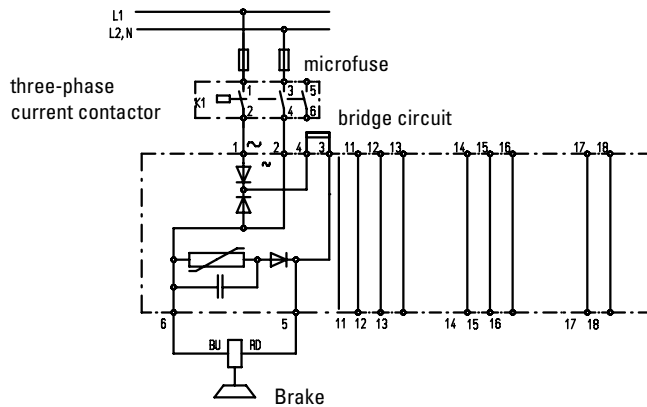

Technical data

Coil voltage of the connected brake	DC 24V ... 240V
Max. voltage of supplying alternating current network	AC 550V - 50/60 Hz
Max. Output current I_{eff} at $T_A = < 50^\circ\text{C}$	5 A
Max. Output current I_{eff} at max. T_A 85°C	3,6 A
Protection fuse in the AC input voltage line to the rectifier (In the selection of fuse is permissible on the $I^2 t$ limit load integral to eight)	FF 4A microfuse switching capacity H
Permitted limit integral $I^2 t$	700A ² s (t < 10ms)
Max. energy absorption of a shut-off	150 J
Max. continuous power of the internal protective circuit (average value)	5W
Shut-off peak at max. coil current	< 450V
Ambiente temperature T_A	-40° C ... +85° C
Permissible cross section of connection wire	0,2 ... 2,5 mm AWG 24 ... 14
Weight	0,3 kg
Protection class	IP 65 components seal / IP20 terminals
Mark of conformity	CE / RoHS conform

Switching rectifier SGL

Principal circuit diagram



Rev. 03-09

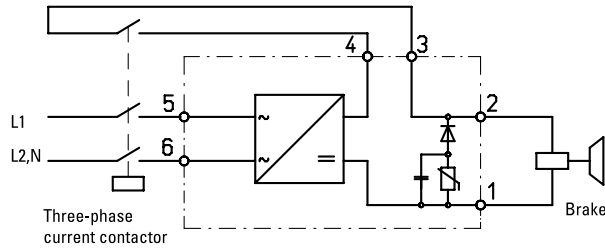

Switching rectification with module SGL

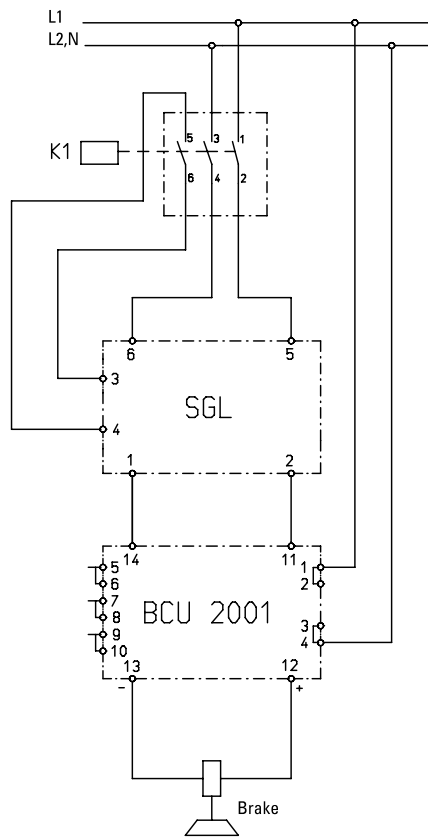

Switching rectification with module SGL combined with the Brake Control Unit BCU2001

Technical data

AC line voltage:	AC 220V...484V; 50/60 Hz
Maximum brake current for 2 s:	8A
Maximum continuous output of the internal protective circuit:	5 W
Permanent brake current:	4A
Time settings by DIP switch:	0,5 s, 1 s, 1,5 s, 2,0 s
Ambient temperature:	-40° C ... +50° C
Protection class:	IP 20

Protective element PE-400/150/5

Principal circuit diagram



Rev. 03-09

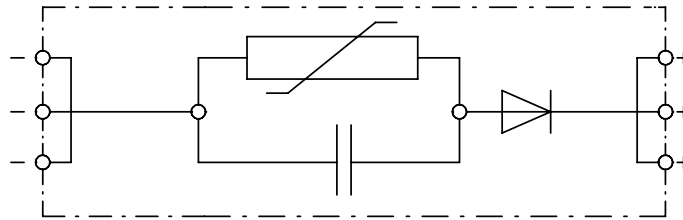

Protective element
PE-400/150/5

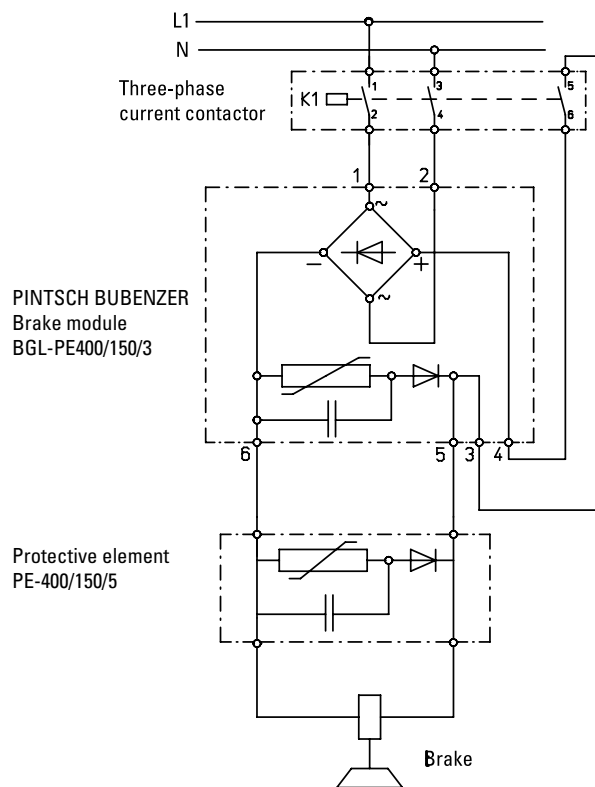

Bridge rectification with
module BGL combined
with the protective element
PE-400/150/5

Technical data

Maximum brake voltage:	DC 400V
Maximum brake current:	5A
Maximum continuous output of the internal protective circuit:	5W
Disconnection peak at maximum coil current:	≤ 450V
Ambient temperature:	-40° C ... +50° C
Protection class:	IP 20

Brake Control Unit BCU2001



PINTSCH BUBENZER
is certified according to
DIN EN ISO 9001:2008



Reliable



High Performance



Robust



Easy Maintenance



Compact



Tried and Trusted

Description Brake Control Unit BCU2001



Main Features

EMC compatibility
Maximum air gap (wear) indication by LED
Maximum air gap indication by relay contact
Function on/off indication by LED
Function on/off indication by relay contact
No sensors on the brake
No sensor wiring to the brake
Perfect retrofit equipment
Directly connectable with PLC systems
AC and DC auxiliary power supplies applicable
Top-hat rail mounted

Applications

Container cranes
Ship winches
Automatic racking systems
Conveyor belts
General electrical drives

Options

Combinable with the switching rectifier SGL in overexcitation mode
Combinable with bridge rectifier BGL-PE400/150/3
Combinable with half-wave rectifier EGL-PE400/150/3

Method

The Brake Control Unit BCU 2001 records characteristic current and voltage variations, which are induced by movements of the armature disk in the magnetic field of the brake coil. In an interference free and reliable manner it evaluates the signal levels in terms of the control state (applied or released) and the maximum air gap (maximum wear)

Important requirements

AC and DC circuit to be switched simultaneously
AC circuit may not be switched alone



Please Note

We supply a detailed operating manual with every order. Nevertheless, we would point out that brakes are only as safe as the servicing and maintenance performed while they are in operation. The guarantee for the correct functioning of our brakes is only valid if the user adheres to the German DIN standard 15434 part 2 (drum and disc brakes, servicing and maintenance in operation), or to comparable standards in his own country.



PINTSCH BUBENZER Service

This includes the verification of the brake selection, if required. A detailed questionnaire is provided for this purpose. Installation and commissioning on-site by PINTSCH BUBENZER service engineers is possible. Drawings as DWG/DXF files for your engineering department are available upon request.

Brake Control Unit BCU2001

Principal circuit diagram



Rev. 03-09

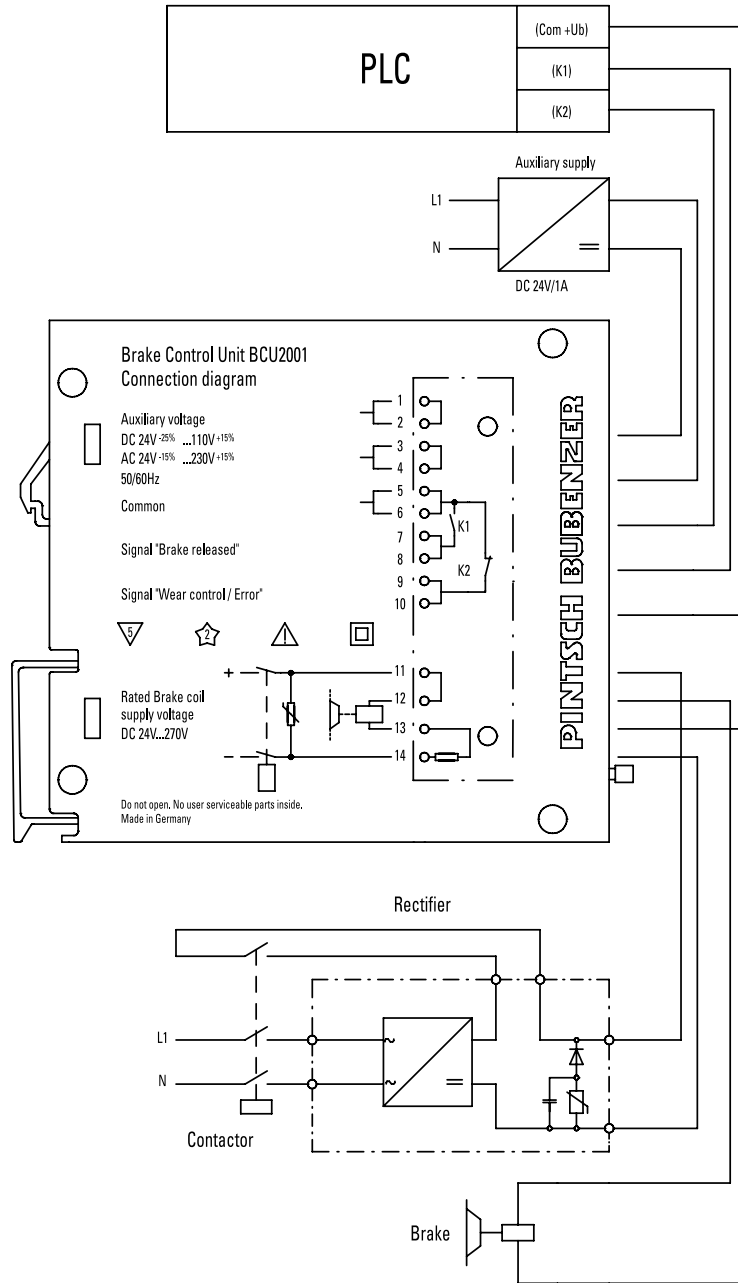

Technical data

Permissible coil voltages:	DC 24V...396V
Ambient temperature:	-40° C ... +50° C
Protection class:	IP 20
Permissible auxiliary power supplies:	AC 24 V -15% ... AC 230 V +15% DC 24 V -25% ... DC 110 V +15%

Drum Brakes



PINTSCH BUBENZER
is certified according to
DIN EN ISO 9001:2008

- 

DIN
Acc. to DIN 15435
- 

Reliable
- 

High Performance
- 

Robust Design
- 

Tried and Trusted

Description Drum Brakes



Main Features

According to DIN 15435 standard
Continuously adjustable brake spring enclosed in a square tube with torque scale
Self-lubricating bushings mean brakes are easy to service, no greasing necessary
Equal air gap by adjustable lever stops
Up to size 400: Levers and base plate made of nodular cast iron
From size 500: Levers and base plate made of welded steel
Different thrusters
Aluminum brake shoes acc. DIN 15435 Bl. 2 with non-asbestos, organic linings
Shoe clamping springs which prevent brake shoes from tilting when released
Pins and main spindle of stainless steel
Uncoated parts and screws galvanized and plated

Options

Automatic wear compensator
Limit switch release control
Limit switch wear control
Limit switch manual release
Manual release lever with or w/o stop
Monitoring systems (e.g. VSR/CMB)
Brake drums with hubs or couplings
Weather execution (special paint and coating) for outdoor use

Thrusters, Technical Data

Thruster Type	Power (W)	Curr. (A) at 400 V	Weight (kg)
Ed 23/5	165	0,5	10
Ed 30/5	200	0,5	14
Ed 50/6	210	0,5	23
Ed 80/6	330	1,2	24
Ed 121/6	330	1,2	39
Ed 201/6	450	1,3	39
Ed 301/6	550	1,4	40

Data supplied by thruster manufacturer, please take higher start current into consideration, fuses to be minimum 2A



Please Note

We supply a detailed operating manual with every order. Nevertheless, we would point out that brakes are only as safe as the servicing and maintenance performed while they are in operation. The guarantee for the correct functioning of our brakes is only valid if the user adheres to the German DIN standard 15434 part 2 (drum and disc brakes, servicing and maintenance in operation), or to comparable standards in his own country.



PINTSCH BUBENZER Service

This includes the verification of the brake selection, if required. A detailed questionnaire is provided for this purpose. Installation and commissioning on-site by PINTSCH BUBENZER service engineers is possible. Drawings as DWG/DXF files for your engineering department are available upon request.

Drum Brake Type EBN

Dimensions (DIN 15435) and technical data



Rev. 03-16

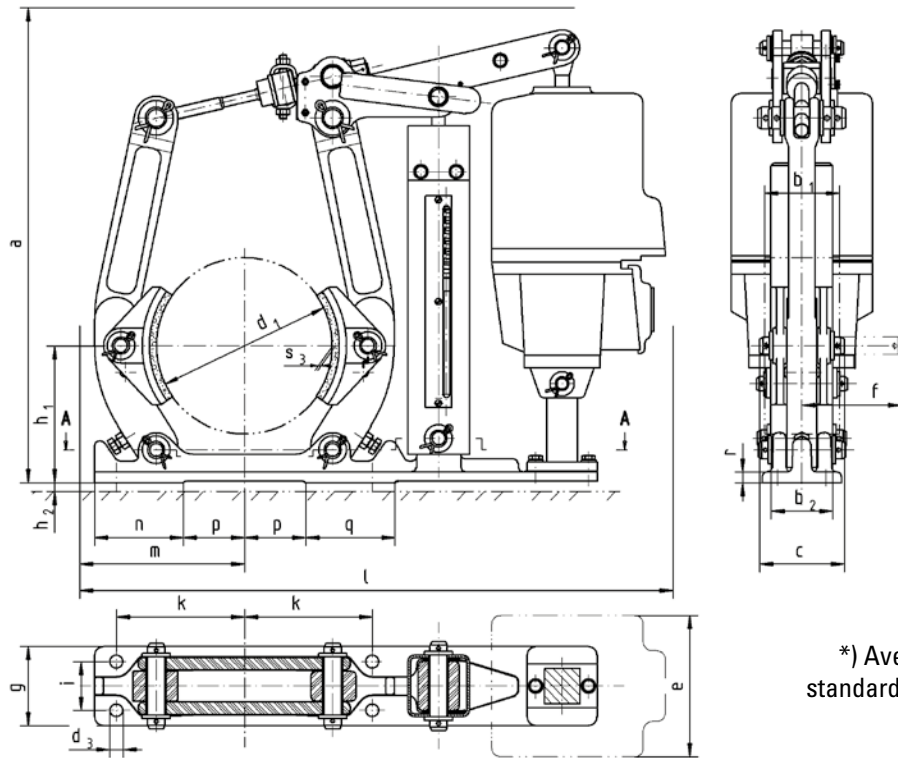

f = required space for removing brake shoe pin

*) Average friction factor of standard material combination

All dimensions in mm
Alterations reserved without notice

Brake type	Thruster type	M_{BRmax} (Nm) $\mu=0,4^*$	a_{max}	b_1	b_2	c	d_1	d_3	e	f	g	h_1	h_2	i	k	l_{max}	m	n	p	q	r	s_3	kg	
EBN 200-23/5	Ed 23/5	300	500	75	70	96	200	14	160	115	90	155	5	55	145	665	185	100	70	100	12	1	22	
EBN 200-30/5	Ed 30/5	380	563						195							705								
EBN 200-50/6	Ed 50/6	600																						
EBN 250-23/5	Ed 23/5	320	500	95	90	115	250	18	160	135	100	185	5	65	180	770	205	105	95	105	13	1,2	28	
EBN 250-30/5	Ed 30/5	450	572						195							810								
EBN 250-50/6	Ed 50/6	750	582																					
EBN 250-80/6	Ed 80/6	1200	665	118	110	140	315	18	160	195	165	110	225	5	80	920	300	110	133	240	13	1,2	68	
EBN 315-30/5	Ed 30/5	540							195							1000								
EBN 315-50/6	Ed 50/6	1000							240							990								
EBN 315-80/6	Ed 80/6	1650	790	150	140	167	400	22	195	195	140	270	10	100	270	1075	310	135	165	280	15	1,5	82	
EBN 315-121/6	Ed 121/6	2500							240						1065									
EBN 400-50/6	Ed 50/6	1100																						
EBN 400-80/6	Ed 80/6	1700	830	190	180	210	500	22	195	245	170	330	10	130	325	1245	370	155	210	315	20	1,5	122	
EBN 400-121/6	Ed 121/6	2650							240															
EBN 400-201/6	Ed 201/6	4000																						
EBN 500-50/6	Ed 50/6	1090	990	236	225	250	630	27	195	240	300	220	410	10	170	400	1320	450	150	280	170	25	2	196
EBN 500-80/6	Ed 80/6	1870							240															
EBN 500-121/6	Ed 121/6	3010																						
EBN 500-201/6	Ed 201/6	5120	1120	265	255	280	710	27	240	335	240	460	10	190	450	1515	520	250	250	450	25	2	266	
EBN 630-121/6	Ed 121/6	3040							240															
EBN 630-201/6	Ed 201/6	4870							1015															
EBN 630-301/6	Ed 301/6	6210	1120	265	255	280	710	27	240	335	240	460	10	190	450	1515	520	250	250	450	25	2	266	
EBN 710-121/6	Ed 121/6	3450							240															
EBN 710-201/6	Ed 201/6	5510																						
EBN 710-301/6	Ed 301/6	6920																						

Drum Brake Type PBNi

Brake release by pneumatic cylinder
 Dimensions (DIN 15435) and technical data



Rev. 03-16

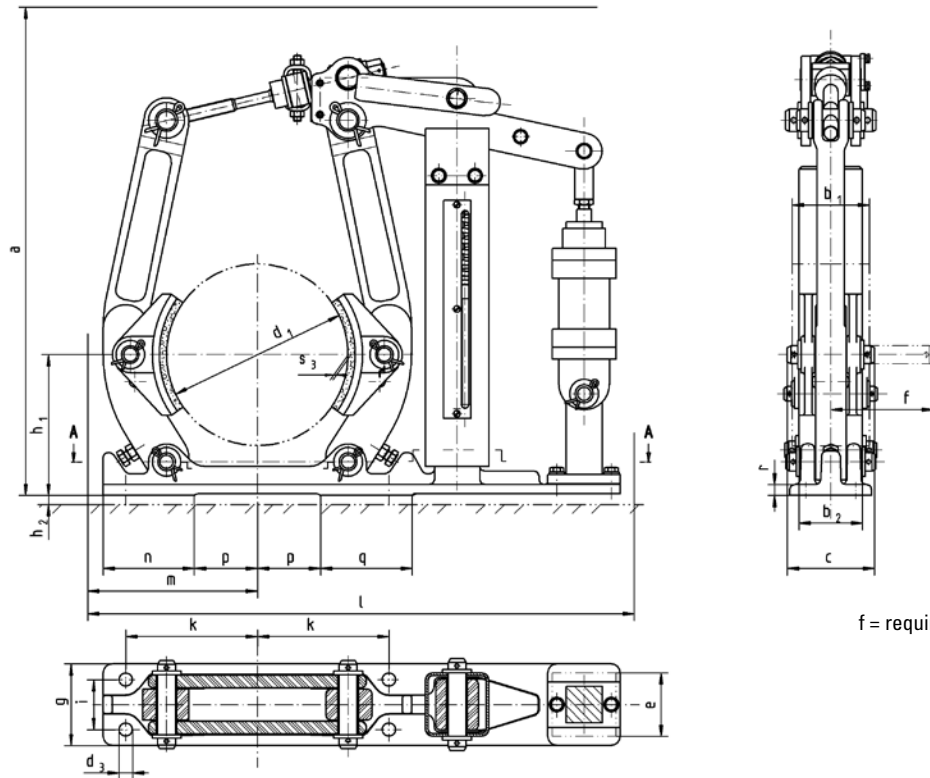

f = required space for removing
 brake shoe pin

Brake is available also as "pneumatic applied" version (PBNd, upon request)

*) Average friction factor of
 standard material combination

All dimensions in mm
 Alterations reserved without notice

Brake type	Operating pressure, bar	$M_{BR \max}$ (Nm) $\mu=0,4^*$	a_{\max}	b_1	b_2	c	d_1	d_3	e	f	g	h_1	h_2	i	k	l_{\max}	m	n	p	q	r	s_3	kg
PBNi 200-30	6	365	500	75	70	96	200	14	50	115	90	155	5	55	145	590	185	100	70	100	12	1	22
PBNi 250-30	6	470	500	95	90	115	250	18	50	135	100	185	5	65	180	700	205	105	95	105	13	1,2	28
PBNi 250-40		65																					
PBNi 315-40	6	1150	665	118	110	140	315	18	65	165	110	225	5	80	220	900	300	110	133	240	13	1,2	47
PBNi 315-50		70																					
PBNi 400-50	6	2000	680	150	140	167	400	22	70	195	140	270	10	100	270	965	310	135	165	280	15	1,5	82
PBNi 400-60		80																					
PBNi 500-50	6	2950	830	190	180	210	500	22	70	245	170	330	10	130	325	1120	370	155	210	315	20	1,5	122
PBNi 500-60		80																					
PBNi 500-80		100																					
PBNi 500-80		1150																					
PBNi 630-60	6	4700	990	236	225	250	630	27	80	300	220	410	10	170	400	1230	450	150	280	170	25	2	196
PBNi 630-80		100																					
PBNi 630-100		1275																					
PBNi 710-60	6	5300	1080	265	255	280	710	27	80	335	240	460	10	190	450	1445	520	150	335	175	25	2	266
PBNi 710-80		100																					
PBNi 710-100		124																					

Drum Brake Type HBNd

Spring released, **hydraulic** applied (Foot pedal)
 Dimensions (DIN 15435) and technical data



Rev. 03-16

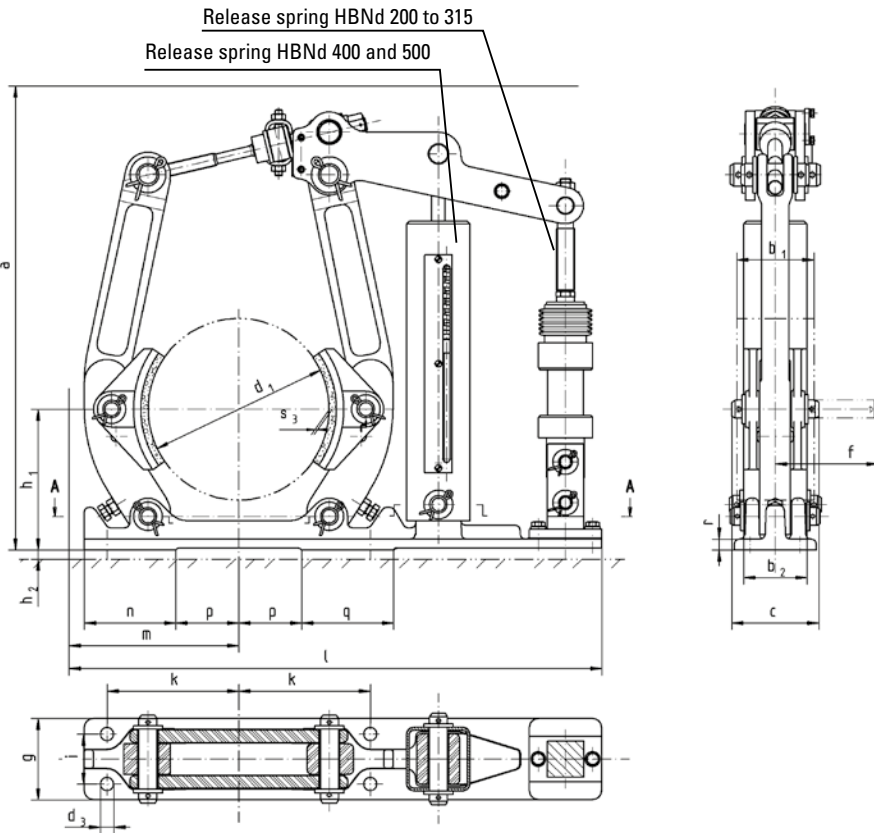

Brake is available also as
 "hydraulic released" version
 (HBNi, upon request)

f = required space for removing
 brake shoe pin

Execution consists of:

0	1 Brake 1 Foot pedal with simple main cylinder	31,75
1	consists of 2 Brakes 1 Foot pedal with simple main cylinder	31,75
2	consists of 2 Brakes 1 Foot pedal with step main cylinder	31,75 28,57

*) Average friction factor of
 standard material combination

All dimensions in mm
 Alterations reserved without notice

Brake type	Execution	$M_{BR\ max} (Nm)$ $\mu=0,4^*$	a_{max}	b_1	b_2	c	d_1	d_3	f	g	h_1	h_2	i	k	l_{max}	m	n	p	q	r	s_3	kg
HBNd 200-25	0	300	500	75	70	96	200	14	115	90	155	5	55	145	590	185	100	70	100	12	1	25
HBNd 200-25	1																					
HBNd 250-25	0	380	500	95	90	115	250	18	135	100	185	5	65	180	700	205	105	95	105	13	1,2	31
HBNd 250-25	1																					
HBNd 315-32	1	800	665	118	110	140	315	18	165	110	225	5	80	220	900	300	110	133	240	13	1,2	49
HBNd 315-25	2	900																				
HBNd 400-32	1	1050	680	150	140	167	400	22	195	140	270	10	100	270	965	310	135	165	280	15	1,5	84
HBNd 400-25	2	1170																				
HBNd 500-32	1	1300	830	190	180	210	500	22	245	170	330	10	130	325	1110	370	155	210	315	20	1,5	126
HBNd 500-32	2	1450																				



The calculated brake torques are based on a foot force of 150 N.

Foot Pedal

for hydraulic brakes



Rev. 09-02

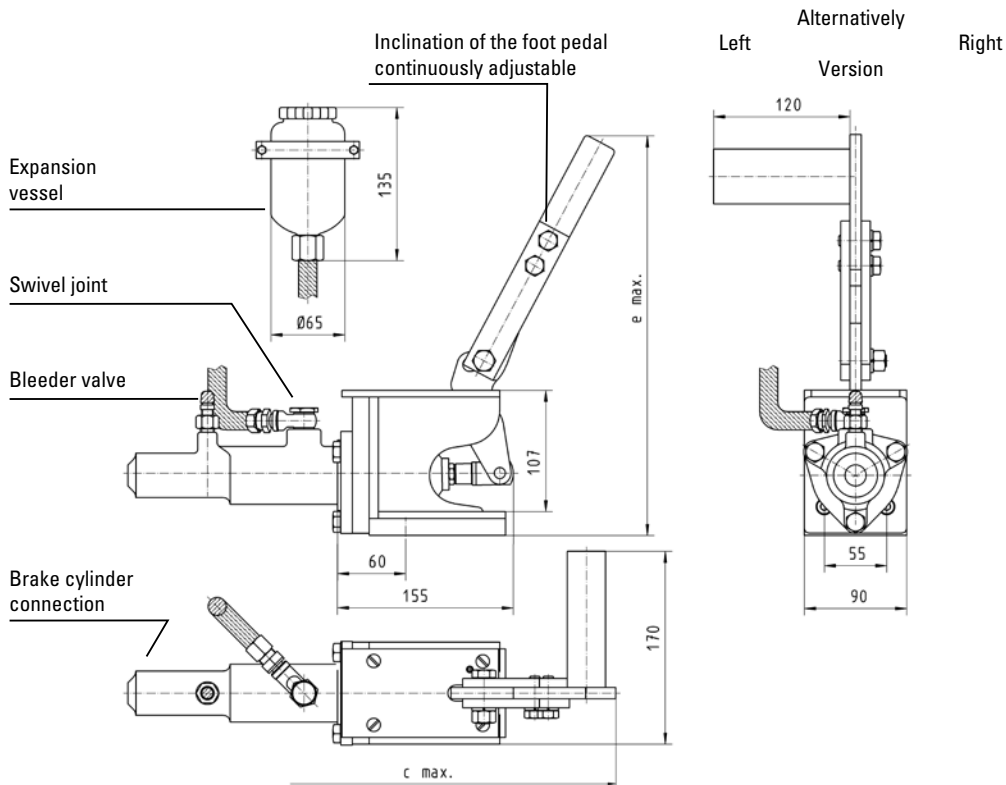

In order to operate two brakes synchronously by one foot pedal, the pipe connections from the foot pedal to each brake must be of the same length.

Scope of supply:

- Brake with built-in slave cylinder, bleeder valve and straight screw union for the connection of:
- One high-pressure hose, 500 mm long, with straight screw union, for connection to the pressure line.
- Expansion vessel with straight screw union.
- Foot pedal with attached master cylinder, a swivelling screw-fitting for the connection of the expansion vessel and a bleeder valve.
- Two high-pressure hoses, 300 mm long, for the connections of the master-cylinder pressure line and slave-cylinder pressure line to the expansion vessel. All the screw unions are arranged for pipe outer dia 10 mm. Pipes and other connection elements are not scope of supply but can be supplied if required.

Hydraulic foot pedal for the installation in cabin floors

Execution	a	b	c _{Max}	d	e _{Max}	Weight kg
1 with simple main cylinder	300	60	485	6	330	6,8
2 with two step cylinder	355	40	540	21	345	9,8

PistonØ	ca. Pressure (at 150N foot force)
25,4	24 bar
28,5	18 bar
31,8	15 bar
38,0	10 bar



Please observe the notes on the following page for the piping and commissioning of the system

Foot Pedal

Notes on the piping and commissioning



Rev. 09-02

General remarks:

Only brake fluid as specified in SAE J-1703e and DOT3 / DOT4 may be used. The use of even slight additions of hydraulic fluid or other mineral oils (residues in unclean pipework) leads, in every case, to the destruction of the seal elements and invalidates any guarantee granted by the manufacturer.

1) Master Cylinder

This cylinder may only be installed in a horizontal position, with connection on top for the expansion vessel (swivelling screw fitting). The high-pressure hose to the expansion vessel must not be kinked downwards but must be laid in a constantly ascending manner.

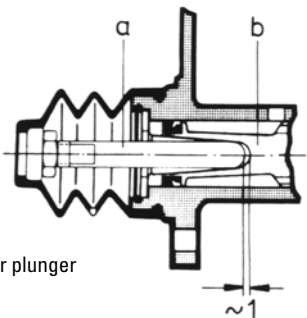

Master-cylinder plunger
(part-view)

When actuated, the foot pedal is held by a pressure spring in the "off"-position against a stop, whereby there should be about 1 mm play between the plunger (a) and the top of the piston (b). This is to be taken into consideration if the factory setting of the stop has been disturbed.

2) Slave Cylinder (Brake)

Installation is possible in any position but the air bleed cock must always be arranged at the highest point. The slave cylinder is to be connected to the pressure line by the high-pressure hose supplied to allow movement of the cylinder when the brake is actuated.

3) Pipework

Material: Precision pipe as specified in DIN 2391, annealed and descaled. Dimensions dia. 10x1. Pipe bends are to be fabricated in a pipe bending device to avoid cross-sectional restrictions. After cutting to size and before laying, pipe sections are to be thoroughly flushed out (spirit) and blown through.

If possible, pressure lines are to be laid with a slight slope. If air pockets through ascending and descending loops cannot be avoided, a bleeding facility must be provided at the highest point.

4) High-pressure hoses

These hoses must be resistant to brake fluid. They must not be painted and are to be shielded from ambient heat.

5) Brake fluid

The brake fluid assures reliable operation down to -40°C . Depending on the quality, the wet boiling point (after water has been absorbed from the air) is between 140 and 155°C .

6) Filling and bleeding of the system

a) without filling and bleeding unit

Fill expansion vessel and in the subsequent filling and bleeding operation ensure that there is always sufficient fluid in the vessel by topping up. The air from the line to the master cylinder rises automatically when the line has been laid correctly. Press the foot pedal right down on the stop once or twice and with the pedal fully actuated first bleed the master cylinder. Close the bleeder valve.

Then open the valve at the slave cylinder (1-2 turns), fit transparent bleed tube and place other end in a receptacle. Pump foot pedal until air bubbles are no longer seen. At the same time, check the level of fluid in the expansion vessel to ensure that no air can be sucked in!

Close bleeder valve and actuate brake several times via the pedal. Then repeat bleeding procedure. The fluid pumped through during the bleeding procedure should not be reused.

b) with filling and bleeding unit (ATE, FAG or similar)

Small, moderately priced units are available on the market which can be connected to the expansion vessel and force the fluid under pressure through the system. Through the flexible separation of fluid and compressed air, the two elements cannot affect each other.

Advantage: The complete procedure can be carried out by one person only. Filling and bleeding will be quicker, safer and more straight forward. The filling and bleeding units come with operating instructions which must be followed exactly when working with such units.

Drum Brake Type EBH

Dimensions (DIN 15435) and technical data



Rev. 03-16

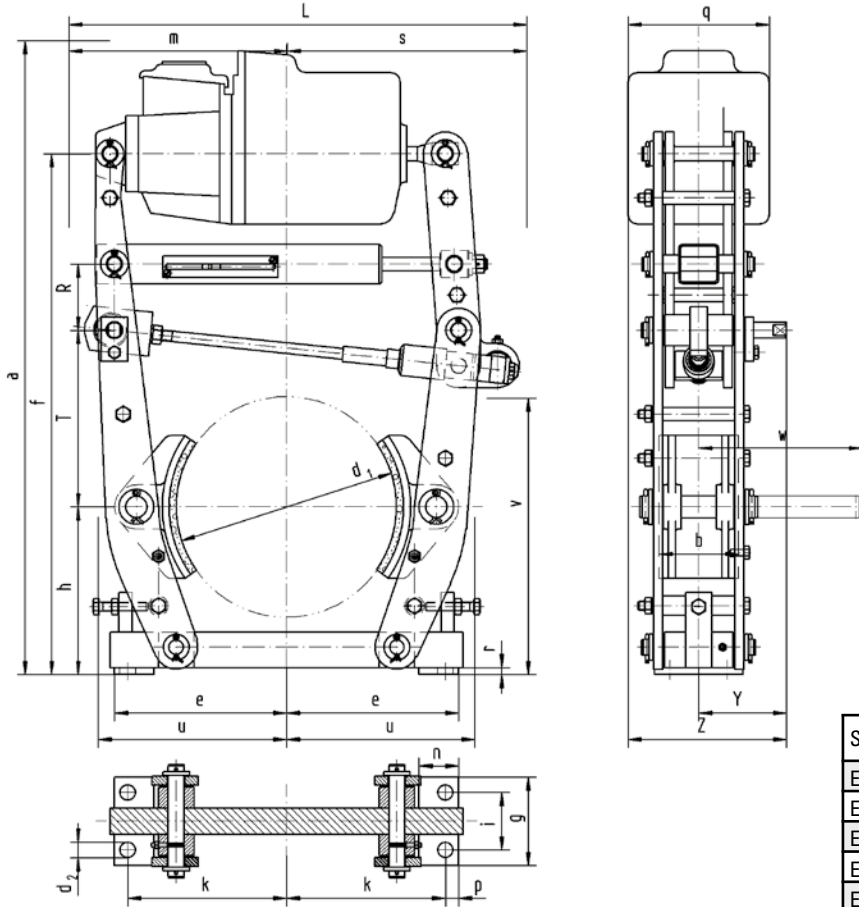

W = required space for removing brake shoe pin

Size	T	R	Y	Z	Weight (kg)
EBH 200	190	55	95	190	17
EBH 250	200	75	105	210	23
EBH 315	288	75	125	250	36
EBH 400	305	100	140	280	70
EBH 500	370	116	170	340	130
EBH 630	upon request				
EBH 710	upon request				

*) Average friction factor of standard material combination

All dimensions in mm
Alterations reserved without notice

Brake type	Thruster type	$M_{BR\ max}$ (Nm) $\mu=0,4^*$	a	b	c	d ₁	d ₂	e	f	g	h	i	k	L	m	n	p	q	r	s	u	w
EBH 200-23/5	Ed 23/5	200	640	70	110	200	14	165	520	90	160	55	145	400	190	45	15	160	8	210	180	115
EBH 200-30/5	Ed 30/5	280												485	220					265		
EBH 250-23/5	Ed 23/5	240	710	90	130	250	18	200	590	100	190	65	180	440	210	45	15	160	8	230	215	135
EBH 250-30/5	Ed 30/5	310												505	235					270		
EBH 250-50/6	Ed 50/6	510												600	260			340				
EBH 315-23/5	Ed 23/5	260	870	110	170	315	18	245	738	110	230	80	220	610	280	50	20	160	10	330	265	165
EBH 315-30/5	Ed 30/5	410												670	290					380		
EBH 315-50/6	Ed 50/6	600	910	140	200	400	22	305	845	140	280	100	270	690	300	135	25	195	10	390	320	195
EBH 315-80/6	Ed 80/6	1120												870	290					380		
EBH 400-50/6	Ed 50/6	700	1010	140	200	400	22	305	845	140	280	100	270	690	300	135	25	195	10	390	320	195
EBH 400-80/6	Ed 80/6	1410												870	400					470		
EBH 400-121/6	Ed 121/6	2000	1000											870	400			240		470		
EBH 500-50/6	Ed 50/6	800	1120	180	250	500	22	360	954	170	340	130	325	740	320	150	30	195	12	420	400	245
EBH 500-80/6	Ed 80/6	1750												740	320					490		
EBH 500-121/6	Ed 121/6	2200	1110	180	250	500	22	360	954	170	340	130	325	900	410	150	30	240	12	490	400	245
EBH 500-201/6	Ed 201/6	4000												900	410					490		

Enclosures

For drum brakes type EBN – Dimensions and executions



Rev. 11-03

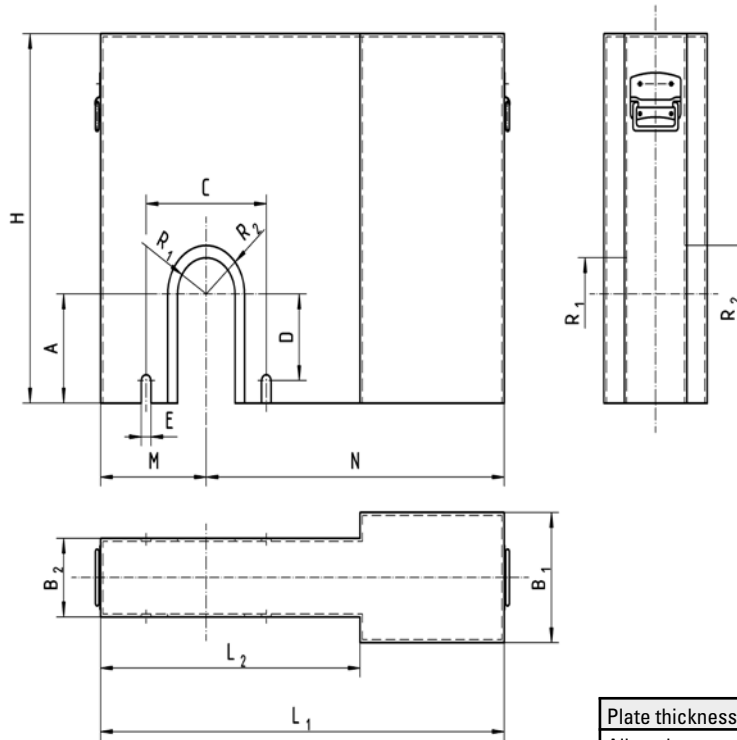

Plate thickness = 1,5 mm
 All enclosures are provided with handles
 Other dimensions upon request

All dimensions in mm
 Alterations reserved without notice

Brake type	A	B ₁	B ₂	C	D	E	H	L ₁	L ₂	M	N	R _{max}	
EBN 200-23/5	150	180	130	200	118	10	530	690	460	195	495	90	
EBN 200-30/5		215											535
EBN 200-50/6		215											535
EBN 250-23/5	180	180	130	250	143	10	530	810	560	220	590	110	
EBN 250-30/5		215											620
EBN 250-50/6		215											620
EBN 250-80/6		215											620
EBN 315-30/5	220	180	170	315	179	12	700	960	700	320	640	140	
EBN 315-50/6		215											710
EBN 315-80/6		260											710
EBN 315-121/6		260											710
EBN 400-50/6	260	215	180	400	205	12	710	1100	800	320	780	180	
EBN 400-80/6		260											780
EBN 400-121/6		260											780
EBN 400-201/6		260											780
EBN 500-121/6	320	280	240	500	260	12	900	1280	930	400	880	230	
EBN 500-201/6													230



When ordering please advise: Brake type, Dimension "R₁ and R₂".

Enclosures

For drum brakes type EBN – Dimensions and executions



Rev. 11-03

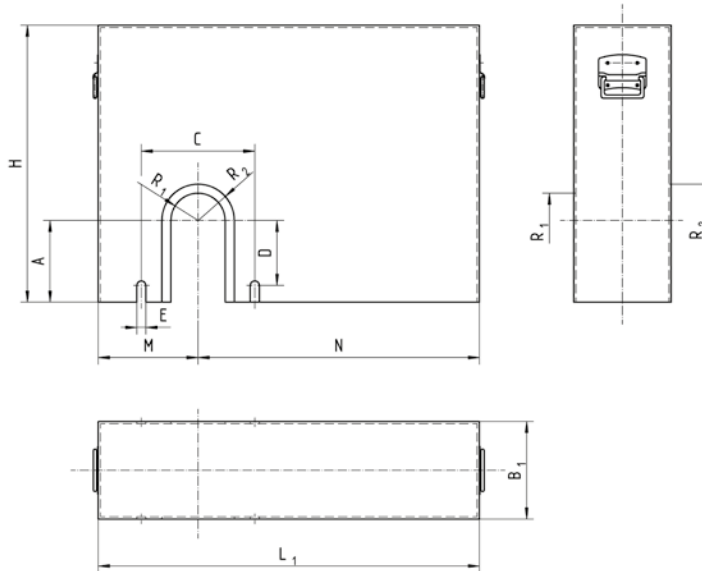

Plate thickness = 1,5 mm
 All enclosures are provided with handles
 Other dimensions upon request

All dimensions in mm
 Alterations reserved without notice

Brake Type	A	B	C	D	E	H	L ₁	M	N	R _{max}		
EBN 200-23/5	150	180	200	118	10	530	690	195	495	90		
EBN 200-30/5		215										
EBN 200-50/6												
EBN 250-23/5	180	180	250	143	10	530	810	220	590	110		
EBN 250-30/5												
EBN 250-50/6		215									610	840
EBN 250-80/6												
EBN 315-30/5	220	180	315	179	12	700	960	320	710	140		
EBN 315-50/6		215										
EBN 315-80/6						1030						
EBN 315-121/6		260				830						
EBN 400-50/6	260	215	400	205	12	710	1100	320	780	180		
EBN 400-80/6												
EBN 400-121/6						830						
EBN 400-201/6		260										
EBN 500-50/6	320	280	500	260	12	880	1280	400	880	230		
EBN 500-80/6												
EBN 500-121/6											900	
EBN 500-201/6												
EBN 630-121/6	400	280	630	325	14	1080	1350	470	880	290		
EBN 630-201/6												
EBN 630-301/6												
EBN 710-121/6	450	320	710	370	14	1150	1530	530	1000	330		
EBN 710-201/6												
EBN 710-301/6												



When ordering please advise: Brake type, Dimension "R₁ and R₂".

Band Brake Type BHB

Dimensions and technical data



Rev. 11-04

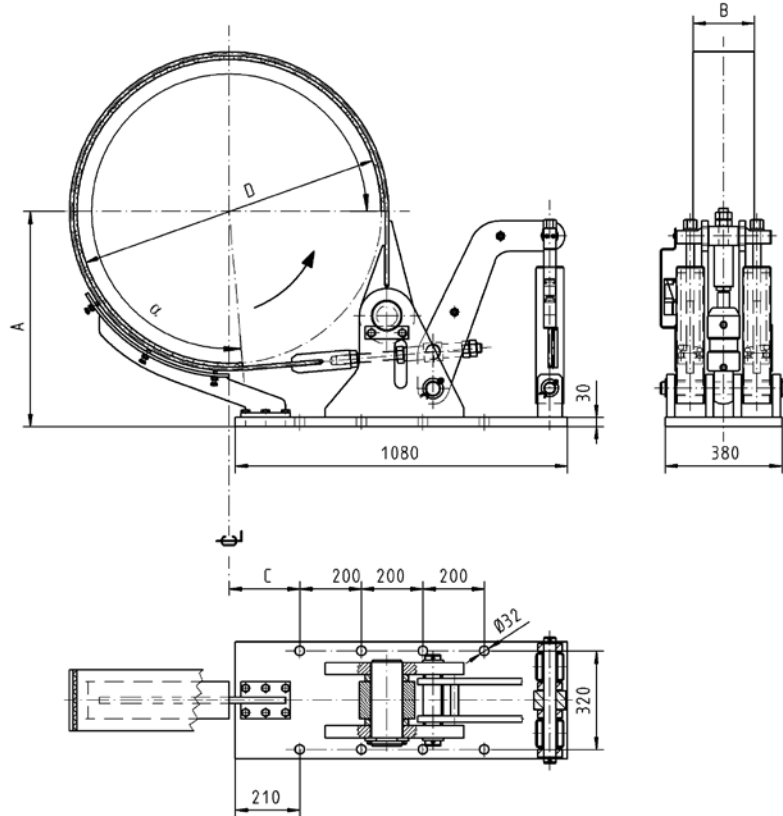

Other diameters and release by thruster upon request.

*) Average friction factor of standard material combination

All dimensions in mm
Alterations reserved without notice

Brake type	A	D	C	E	M_{br} (kNm) $\mu=0,4^*$	Band width (B)	
BHB 990-80/60	700	990	20	230	min. 60	120	
					<100		160
					<160		200
					max. 203		
BHB 1110-80/60	760	1110	80	290	min. 70	120	
					<140		160
					<180		200
					max. 230		
BHB 1240-80/60	825	1240	145	355	min. 60	120	
					<160		160
					<200		200
					max. 253		
BHB 790-80/60 (Wrap angle 265° !)	600	790	-30	180	min. 60	120	
					<100		160
					max. 130		200

Band Brake Type BHB

Hydraulic power unit for one or more brakes



Rev. 09-02

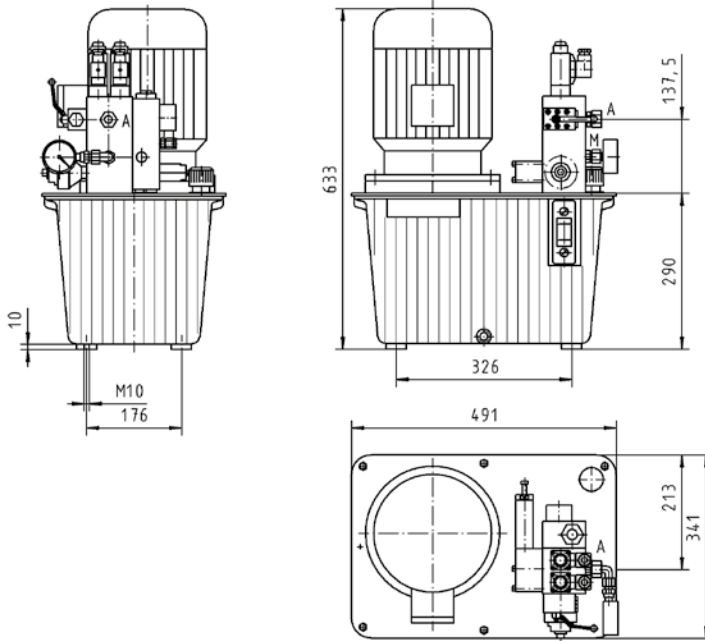

Example:	
Motor:	3 kW
Pump:	9 l/min
Pressure:	180 bar
Tank:	30 l

The flow diagram shows the general arrangement of the hydraulic power unit, including hand pump for emergency manual release of the brakes.

The two solenoid valves are connected directly in parallel (redundancy). After the nominal pressure is reached, the idler valve switches into idle running. The motor is continuously energized. Pressure switch, temperature switch, space heater and other accessories are available as options.

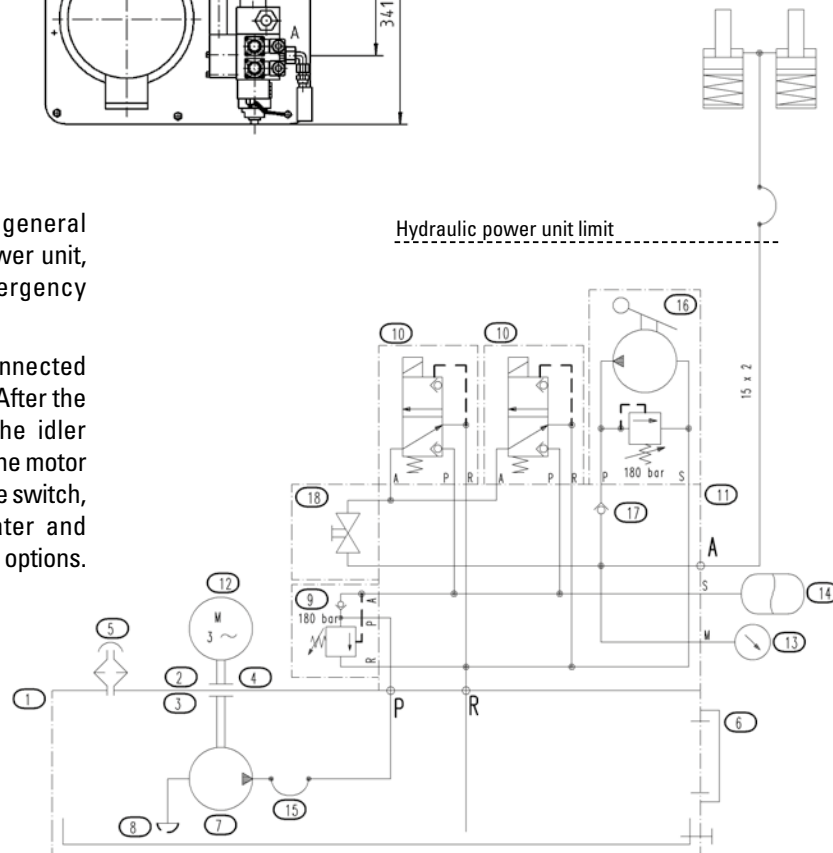

All dimensions in mm
Alterations reserved without notice



We supply a complete hydraulic and electric diagram according to the order specification with every order.

Drum Brakes EBA Series



PINTSCH BUBENZER
is certified according to
DIN EN ISO 9001:2008

- 

AISE
Acc. to NEMA and AISE
- 

Reliable
- 

High Performance
- 

Robust Design
- 

Tried and Trusted

Description Drum Brakes EBA Series



Standard Features

Stepless, Adjustable, External Torque Spring
Non-Latching, Manual Release Handle
Stainless Steel Spindle and Pivot Pins
Self-Lubricated Bushings
Steel Brake Shoes with Non-Asbestos Linings
Adjustable Centering
Torque Adjustable to 50% of Maximum Rating
High Duty Cycle - Up to 2000 Cycles Per Hour
230/460 VAC - 3 Phase - 60 Hz (Available 110-690 VAC)
Standard Temperature Rating from -13° to 122° F

Options

Adjustable Time Delays for Both Setting and/or Releasing
Special High and Low Temperature Fluids (-40° to 176° F)
Automatic Wear Compensator
Limit Switches for Release, Set, or Manual Release
Monitoring Systems (VSR-2 / CMB-2)
DC Thrusters (Available 24-500 VDC)
Variable Frequency, Foot Pedal Controlled Braking
Flameproof, Explosion Proof Available (110-1000 VAC)

Thrusters Data

Thruster Type	Power (W)	Current @ 460 VAC	Weight (lbs)
Ed 12/4	160	0,44	20
Ed 23/5	165	0,44	22
Ed 30/5	200	0,44	31
Ed 50/6	210	0,44	51
Ed 80/6	330	1,04	53
Ed 121/6	330	1,04	86
Ed 301/6	550	1,40	88
Ed 301/12	550	1,40	88
Thruster	Power	250 VDC	Weight
Eg 50/6	350	1,6	60
Eg 80/6	330	1,5	60
Eg 121/6	330	1,5	95
Eg 301/6	470	2,2	95
Eg 301/12	470	2,2	97

Torque Range

Drum Size (inches)	Torque Range (lb-ft)
6	25 - 110
8	90 - 260
10	115 - 330
13	200 - 750
16	400 - 1250
19	1070 - 2138
23	2120 - 4240
30	4500 - 9000



Please Note

We supply a detailed operating manual with every order. Nevertheless, we would point out that brakes are only as safe as the servicing and maintenance performed while they are in operation. The guarantee for the correct functioning of our brakes is only valid if the user adheres to the German DIN standard 15434 part 2 (drum and disc brakes, servicing and maintenance in operation), or to comparable standards in his own country.



PINTSCH BUBENZER Service

This includes the verification of the brake selection, if required. A detailed questionnaire is provided for this purpose. Installation and commissioning on-site by PINTSCH BUBENZER service engineers is possible. Drawings as DWG/ DXF files for your engineering department are available upon request.

Drum Brakes EBA Series

Standard Features



Rev. 03-16

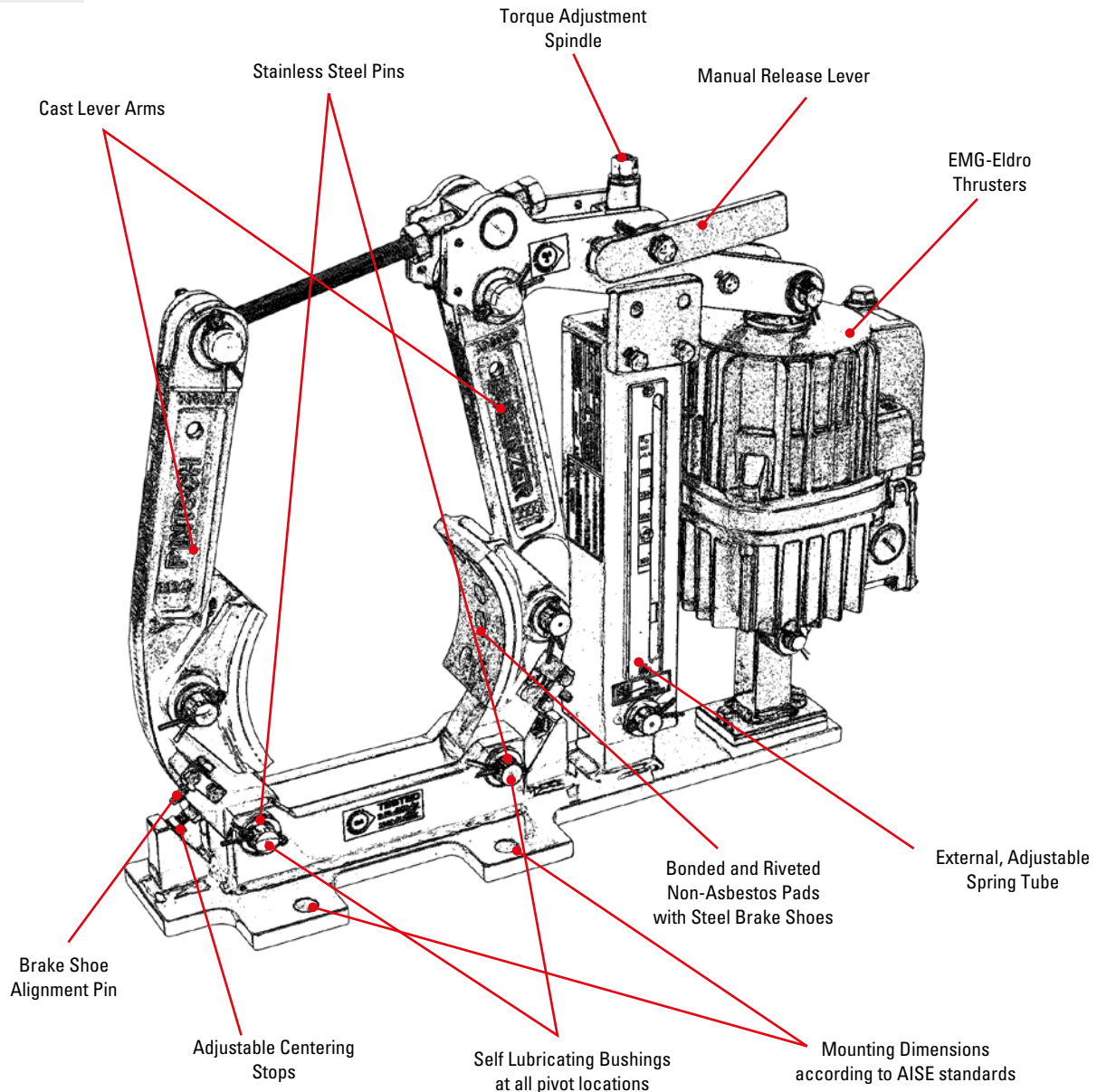

AC Electro-Hydraulic Thruster Activated Drum Brakes

The EBA Series Drum Brakes by Pintsch Bubenzer have been designed with safety, longevity, and durability in mind. Ideally suited for today's AC cranes, the AC thruster provides smooth, reliable stopping power for a variety of applications; from Class F Steel Mill Cranes to everyday light duty workshop cranes. The EBA Series has been designed and built to AISE standards for footprint and elevation, so they are "drop-in" replacements for many existing DC coil brakes as well as other drum brake styles. EBA Series brakes are spring-set, thruster-released, fail-safe brakes that incorporate unique design features which provide higher torque ratings in all sizes compared to the competition. The electro-hydraulic thrusters are sealed units that require little to no maintenance and are a 100% duty rated. Available in a variety of sizes and configurations, thrusters offer soft, even stops with significantly less mechanical impact when compared to DC coil brakes. The smooth, even stopping provided by thrusters make the EBA Series brakes ideal solutions for high duty cycle applications where frequent starting and stopping occur.

EBA Series Drum Brakes

Dimensions and technical data



Rev. 03-16

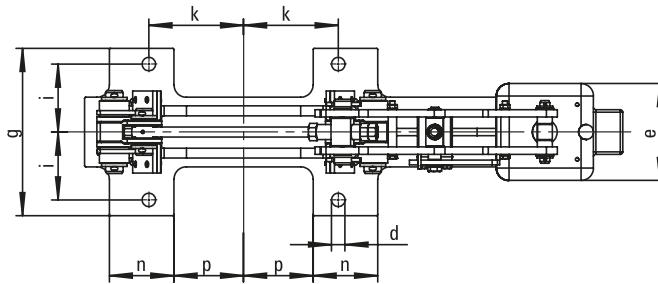
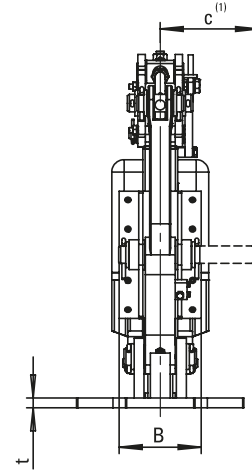
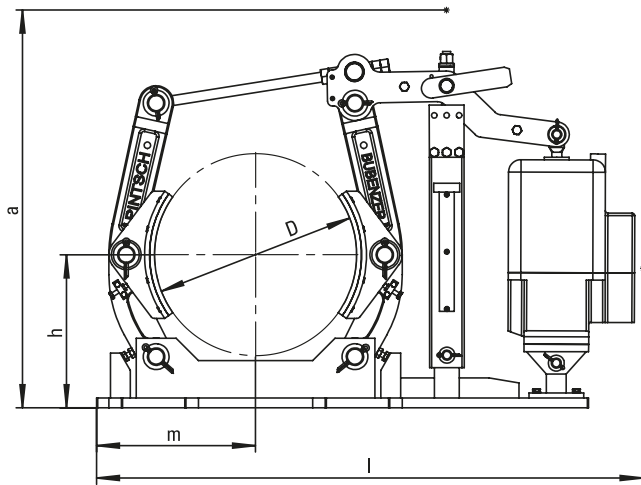

- (1) Minimum space required for removing brake shoe pin
- (2) Average friction factor of standard material combination
- (3) AISE-NEMA does not define a 6-inch drum brake

Alterations reserved without notice

Brake Type	Torque	Drum Size	Shoe Width	Dimensions													Weight	
	$\mu=0.4$ (2)			D	B	h	a	c	d	e	g	t	i	k	l	m	n	p
	lb-ft	(inches)																
EBA 6" - 12/4 (3)	50	6	2.50	5.25	14.75	4.50	0.47	6.00	5.91	0.31	2.25	2.75	19.88	5.31	2.75	2.00	31	48
EBA 6" - 23/5 (3)	110							6.10					21.25					53
EBA 8" - 23/5	180	8	3.00	7.00	21.00	4.50	0.69	6.10	7.25	0.59	2.88	3.25	26.00	7.09	3.00	2.17	79	101
EBA 8" - 30/5	260							6.30										110
EBA 10" - 23/5	230	10	3.50	8.38	21.50	5.50	0.69	6.10	8.00	0.59	3.13	4.00	30.75	8.27	3.50	2.76	95	117
EBA 10" - 30/5	330				23.25			6.30										230
EBA 13" - 30/5	400	13	5.50	9.88	28.50	6.50	0.81	6.30	11.00	0.59	4.50	5.75	35.50	11.02	4.33	4.53	179	210
EBA 13" - 50/6	750							8.66					38.75					230
EBA 16" - 50/6	800	16	6.50	12.13	29.50	8.00	1.06	8.66	13.25	0.79	5.38	7.50	43.00	12.60	5.12	5.51	241	292
EBA 16" - 80/6	1250																	294
EBA 19" - 121/6	2138	19	8.75	13.25	33.25	9.58	1.06	9.50	16.14	0.79	6.50	9.25	51.18	14.58	7.48	7.09	269	355
EBA 23" - 301/6	4240	23	9.50	15.88	38.50	11.87	1.31	9.50	18.75	0.79	8.00	11.75	53.15	16.93	6.77	9.75	502	589
EBA 30" - 301/12	9000	30	13.50	20.75	48.75	13.62	1.56	9.50	23.00	1.18	9.50	15.00	71.65	22.05	10.25	9.84	1515	1600

Brake Wheels

Dimensions and technical data



Rev. 03-16

SYMMETRICAL WHEEL

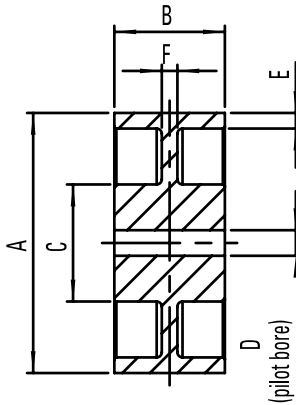

OFFSET WHEEL

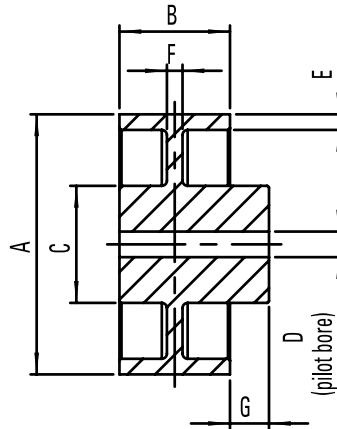

AISE OFFSET WHEEL

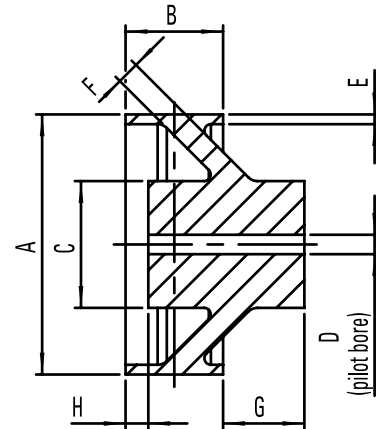

Material: GGG 40 (similar to ASTM A526)

SYMMETRICAL WHEELS

Part #	Diameter A	"B"	"C"	"D"	"E"	"F"	Max Bore	Weight (lbs)
WS6	6"	3.25"	3.00"	.59"	.40"	.40"	1.75"	13
WS8	8"	3.75"	4.50"	.79"	.50"	.50"	3.00"	30
WS10	10"	4.25"	4.50"	.98"	.60"	.60"	3.00"	43
WS13	13"	5.25"	6.25"	1.18"	.70"	.70"	4.00"	99
WS16	16"	8.00"	7.25"	1.38"	.80"	.80"	5.25"	187

OFFSET WHEELS

Part #	Diameter A	"B"	"C"	"D"	"E"	"F"	"G"	Max Bore	Weight (lbs)
WO6	6"	3.25"	3.00"	.59"	.40"	.40"	1.00"	1.75"	15
WO8	8"	3.75"	4.50"	.78"	.50"	.50"	2.00"	3.00"	38
WO10	10"	4.25"	4.50"	.98"	.60"	.60"	1.50"	3.00"	49
WO13	13"	5.25"	6.25"	1.18"	.70"	.70"	1.25"	4.00"	104
WO16	16"	8.00"	7.25"	1.38"	.80"	.80"	1.50"	5.25"	203

AISE OFFSET WHEELS

Part #	Diameter A	"B"	"C"	"D"	"E"	"F"	"G"	"H"	Max Bore	Weight (lbs)
WA8	8"	3.25"	3.875"	.75"	.50"	.625"	3.25"	.50"	2.50"	34
WA10	10"	3.75"	4.875"	.75"	.375"	.875"	3.125"	.875"	3.00"	55
WA13	13"	5.75"	6.81"	8.75"	.50"	.875"	3.375"	1.25"	4.25"	128
WA16	16"	6.75"	6.81"	1.00"	.59"	1.00"	3.125"	2.265"	4.625"	166
WA19	19"	8.75"	7.00"	1.00"	1.125"	1.25"	3.125"	5.625"	4.625"	234
WA23	23"	11.25"	9.50"	1.00"	1.25"	1.50"	3.25"	5.50"	5.00"	326
WA30	30"	14.25"	13.50"	2.00"	1.625"	1.75"	5.625"	7.125"	5.875"	992

Flexible Coupling Type K

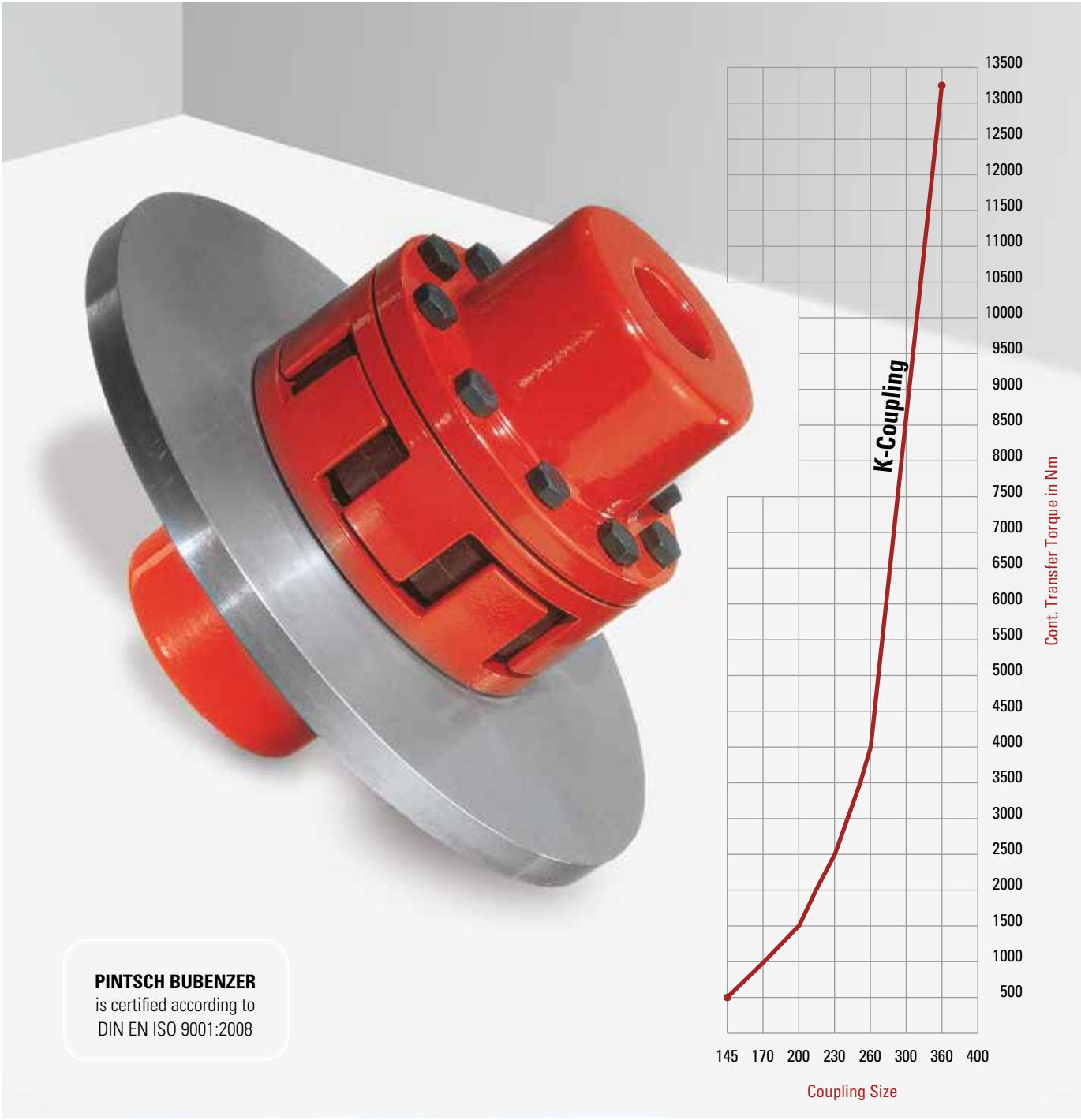

PINTSCH BUBENZER
is certified according to
DIN EN ISO 9001:2008



Torsionally Elastic



Tried and Trusted



High Performance



Robust



Easy Maintenance

Description Coupling Type K



Main Features

- Four component steel coupling, torsionally elastic and puncture-proof
- Transmission of torque via elastic intermediate ring
- Replacement of the elastic intermediate ring or the brake disc without moving any equipment
- Arrangement of the brake disc on the load side to allow the brake torque to be maintained when the motor is disengaged
- Vast selection of coupling sizes and brake disc diameters to satisfy most braking and drive requirements

Options

- Coupling hubs ready bored and keywayed (preferably acc. to DIN 6885)
- Coupling hubs tapered bored
- Coupling hubs with double keyway
- Coupling hubs pilot bored
- Coupling balanced according to ISO 1940-Grade: G 6.3
- Coupling without brake disc

Ordering Example

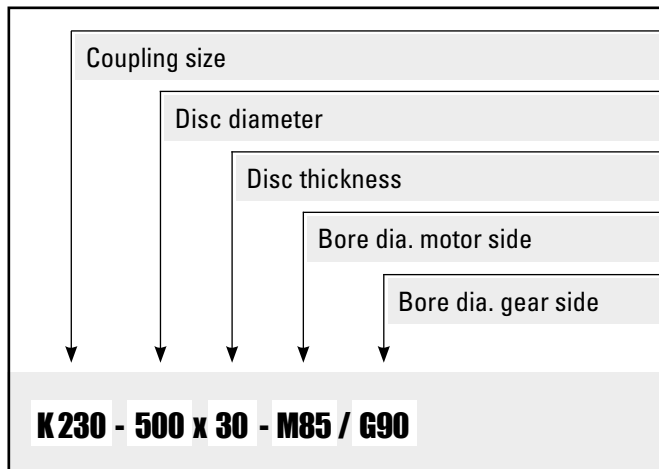

Applications

- These couplings are for use in application with high dynamic loads
- Damping of peak torques and vibrations as well as electrical insulation between motor and gearbox are further reasons for the use of this coupling type
- The standard material of the elastic intermediate ring (Vk60D) is suitable for a temperature range of -30°C...+100°C



Please Note

We supply a detailed operating manual with every order. Couplings are rotating parts and as such a cover must be fitted for the prevention of accidents.



PINTSCH BUBENZER Service

This includes the verification of the brake selection, if required. A detailed questionnaire is provided for this purpose. Installation and commissioning on-site by PINTSCH BUBENZER service engineers is possible. Drawings as DWG/DXF files for your engineering department are available upon request.

Flexible Coupling Type K

Dimensions and technical data



Rev. 12-06

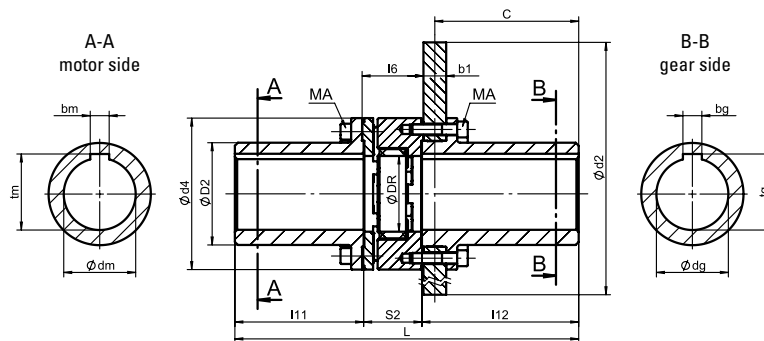

All dimensions in mm
Alterations reserved without notice

Coupling K (size = d4)		145	170	200	230	260	300	360	400		
M_{Br} max.	Nm	1800	2850	4950	7740	11940	17550	29100	40050		
T_{KN} (VK60D)	Nm	600	950	1650	2580	3980	5850	9700	13350		
n_{max} at max. disc \emptyset	min ⁻¹	3800	3400	3000	2700	2400	2200	1750	1750		
d_m max. + d_g max.	mm	65	75	95	110	125	140	160	160		
D_2	mm	92	110	135	160	180	200	225	225		
D_R	mm	67	90	100	115	150	162	215	250		
L	mm	344,5	374,5	454	458,5	518,5	535,5	627,5	627,5		
l_{11}	mm	110	140	170	170	210	210	250	250		
l_{12}	mm	166,5	166,5	207	207,5	212,5	212,5	252,5	252,5		
l_6	mm	71 +2,5	71 +3	81 +3	86 +3,5	101 +4	118 +4	130 +4	130 +4		
S_2	mm	68	68	77	81	96	113	125	125		
C ($b_1 = 30$ mm / 40 mm)	mm	150 / -	150 / -	190 / -	190 / -	195 / -	195 / -	235 / 230	235 / 230		
M_A	Nm	84	84	132	132	206	410	710	710		
Brake disc diameter $d_2 \times b_1$ (mm)	355 x 30	41	Weight						kg		
		0,3973	Moment of inertia						kgm ²		
	400 x 30	47	54	76							
		0,6219	0,656	0,801							
	450 x 30	55	62	84							
		0,9781	1,016	1,158							
	500 x 30		71	93	116	139					
			1,513	1,655	1,782	2,123					
	560 x 30			105	128	150					
				2,484	2,611	2,960					
	630 x 30				143	168	189				
				3,98	4,330	4,704					
710 x 30					185	225					
					6,563	6,92					
800 x 30		Weights and moments of inertia are not binding, referring to the max. finish bore for the sizes 145 to 300 respectively for a finish bore of 120 mm for the sizes 360 and 400.					250	311			
							10,52	11,49			
900 x 30									342	354	
									17,21	17,69	
1000 x 30						376	389				
						25,16	25,65				

Flexible Coupling Type K

Design and permissible misalignments



Rev. 09-02

Design

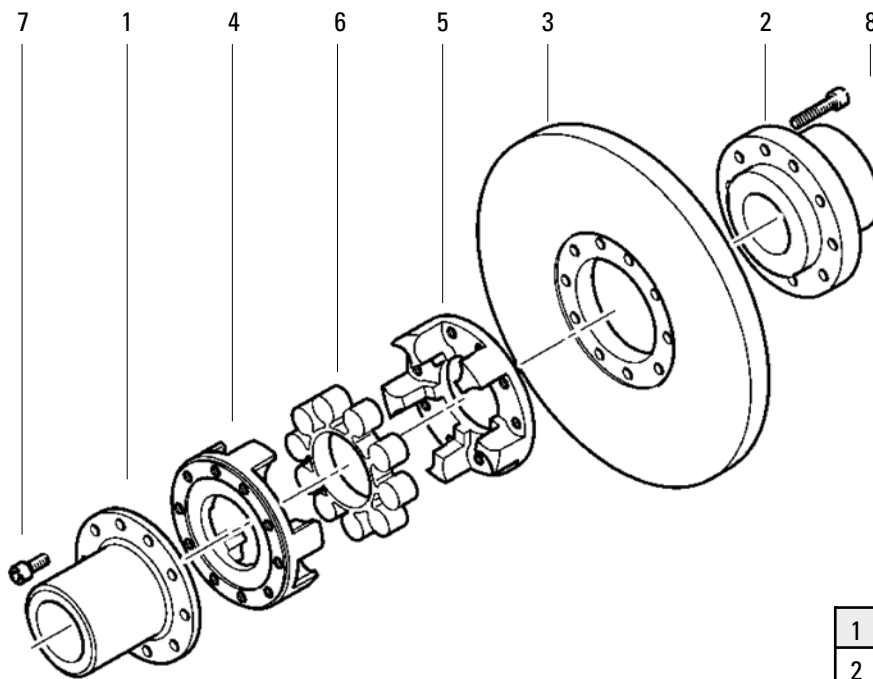

1	Hub, motor side
2	Hub, gear side
3	Brake disc
4	Claw ring, removable
5	Claw ring, removable
6	Elastic intermediate ring
7	Socket head screws
8	Socket head screws

Gear Coupling Type KBT

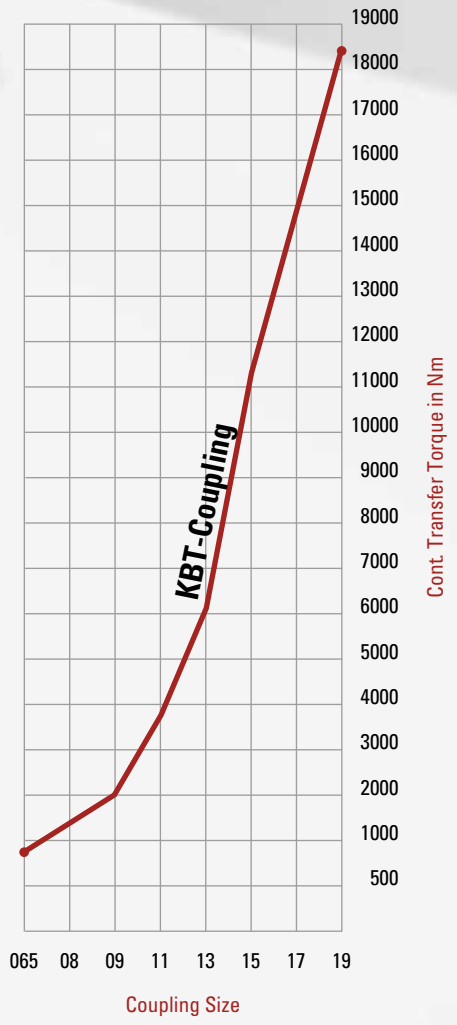

PINTSCH BUBENZER
is certified according to
DIN EN ISO 9001:2008



Torsionally Rigid



Tried and Trusted



High Performance



Robust



Easy Maintenance

Description Coupling Type KBT



Main Features

Steel coupling with special tooth pattern
Torque transmission via internal geared sleeve and external geared hubs
Replacement of the brake disc or the seals without moving any equipment
High temperature resistance
Low wear
Arrangement of the brake disc on the load side to allow the brake torque to be maintained when the motor is disengaged
Vast selection of coupling sizes and brake disc diameters to satisfy most braking and drive requirements

Options

Coupling hubs ready bored and keywayed (preferably acc. to DIN 6885)
Coupling hubs tapered bored
Coupling hubs with double keyway
Coupling hubs pilot bored
Coupling without brake disc

Balancing grade ISO 1940 - G 6.3 is guaranteed for all coupling parts

Ordering Example

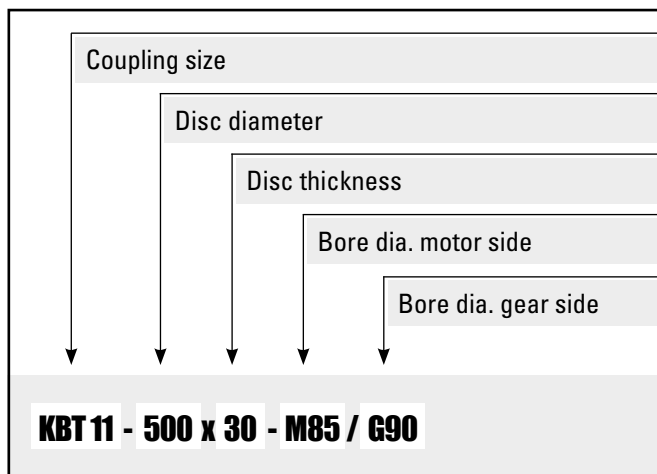

Applications

These couplings are for use in machinery where a torsionally rigid torque is required, especially on frequently varying loads and speeds



Please Note

We supply a detailed operating manual with every order. Couplings are rotating parts and as such a cover must be fitted for the prevention of accidents.



PINTSCH BUBENZER Service

This includes the verification of the brake selection, if required. A detailed questionnaire is provided for this purpose. Installation and commissioning on-site by PINTSCH BUBENZER service engineers is possible. Drawings as DWG/DXF files for your engineering department are available upon request.

Gear Coupling Type KBT

Dimensions and technical data



Rev. 09-02

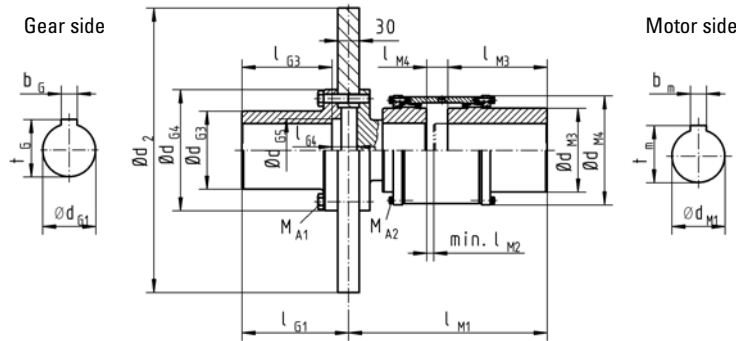

All dimensions in mm
Alterations reserved without notice

Coupling KBT		065	08	09	11	13	15	17	19
M _{Br} max.	Nm	2000	4000	5000	9250	15250	27500	36500	46000
TKN	Nm	800	1600	2000	3700	6100	11000	14600	18400
n _{max} at max. disc Ø	min ⁻¹	3800	3400	2750	2400	2150	2150	1900	1900
d _{G1} max.	mm	55	75	90	110	120	140	160	195
d _{G3}	mm	85	110	130	160	180	200	225	265
d _{G4}	mm	145	170	200	230	260	300	360	400
d _{G5}	mm	68	88	105	130	140	162	184	225
d _{M1} max.	mm	70	85	95	110	130	155	175	195
d _{M3}	mm	100	118	130	151	178	213	235	263
d _{M4}	mm	140	154	161	186	216	254	282	317
l _{G1}	mm	150	150	190	190	195	195	235	235
l _{G3}	mm	127	127	167	167	172	172	212	212
l _{G4}	mm	35	35	35	35	35	35	35	35
l _{M1}	mm	215	280	310	325	350	385	425	470
l _{M2}	mm	7	10	10	10	10	10	10	10
l _{M3}	mm	110	140	146	165	170	190	200	220
l _{M4}	mm	12	30	17	19	23	24	29	32
Brake disc diameter d ₂ x b ₁ (mm)	355 x 30	43			Weight of the coupling with				kg
		0,415			Moment of inertia of the coupling with				kgm ²
	400 x 30	49	62	79					
		0,639	0,73	0,752					
	450 x 30	57	70	87					
		0,996	1,09	1,108					
	500 x 30		79	96	119				
			1,585	1,605	1,783				
	560 x 30			108	131	161			
				2,434	2,611	2,915			
630 x 30			123	146	176	229			
			3,802	3,98	4,283	4,955			
710 x 30				166	196	248	310	393	
				6,213	6,516	7,118	8,351	10,23	
800 x 30					221	274	335	418	
					10,11	10,78	11,94	13,83	
900 x 30		Weights and moments of inertia are not binding, referring to the max. finish bore.						367	450
							17,64	19,53	

Gear Coupling Type KBT

Design and permissible misalignments



Rev. 09-02

Design
(except KBT065)

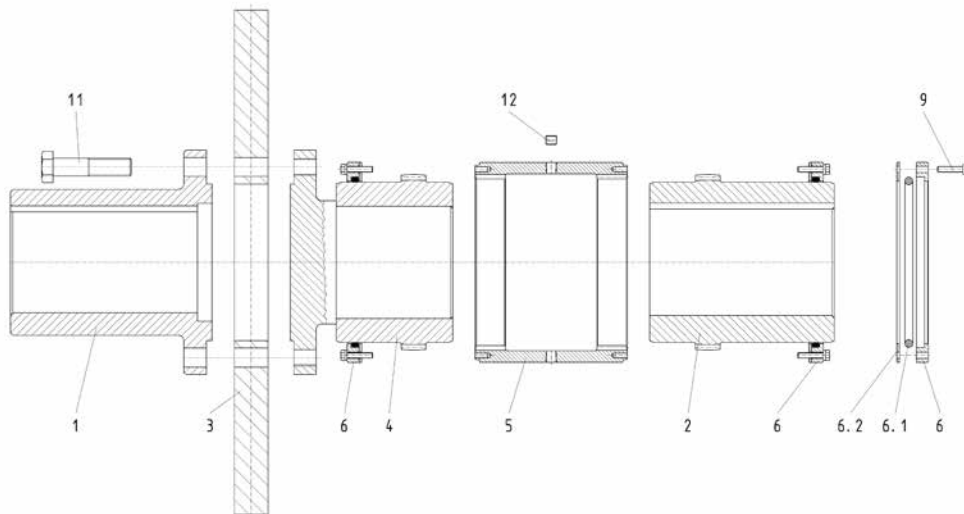

1	Hub, gear side
2	Hub, motor side
3	Brake disc
4	Flange with geared hub
5	Internal geared sleeve
6	End-cap with O-ring (6.1) and gasket (6.2)
9	End-cap screws
11	Fastening bolts
12	Lube plugs

Hub with Brake Disc Type N + NX

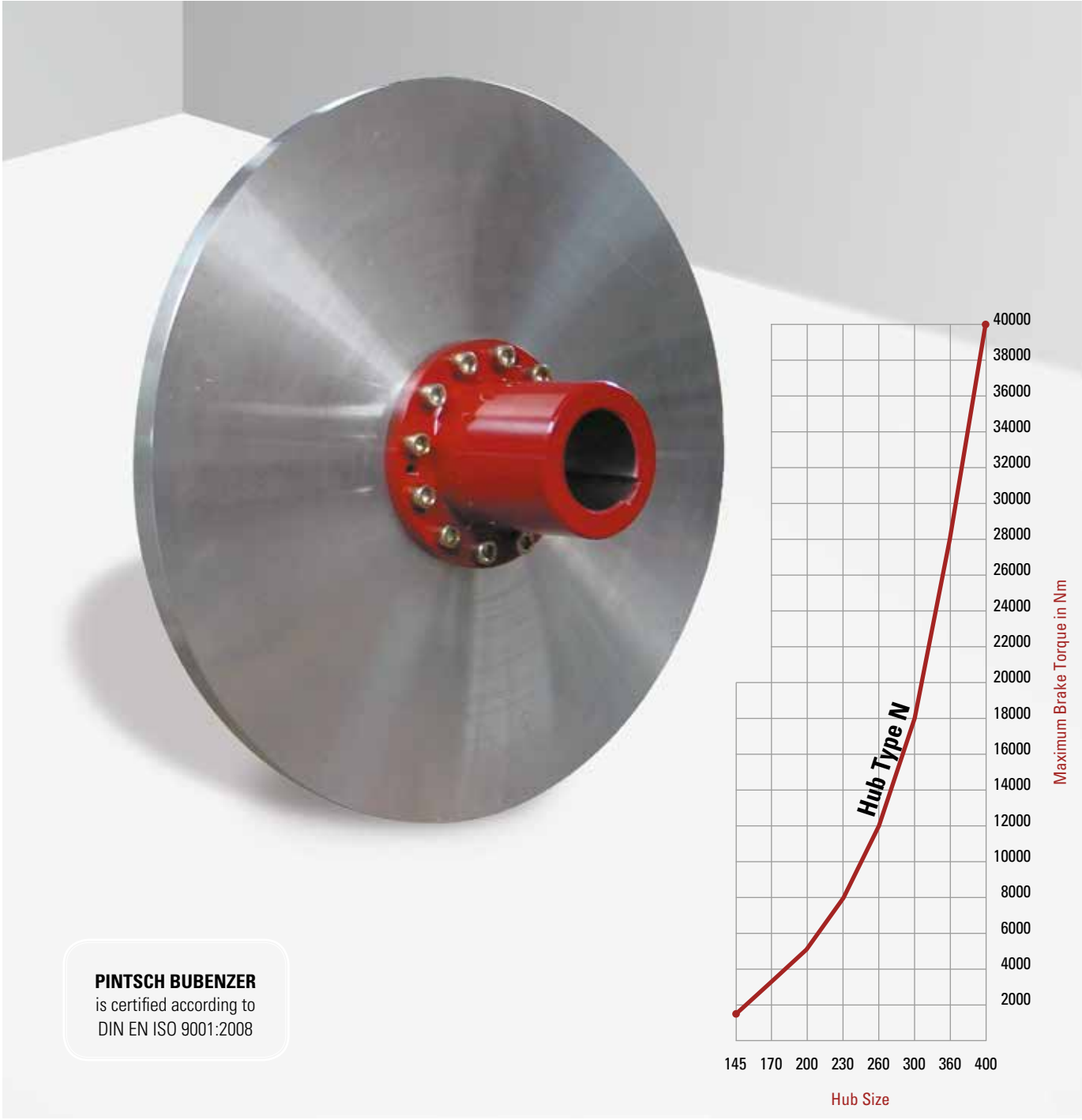

PINTSCH BUBENZER
is certified according to
DIN EN ISO 9001:2008

- Safe
- Tried and Trusted
- Robust
- Easy Maintenance

Description Hub Type N + NX



Main Features

- Hub/disc combination for easy exchange of brake disc (type N)
- High accident prevention by fastening ring, no rotating nuts (type N)
- Exchange of brake disc without removing the hub (type N)
- Simple, one-piece design with 20 mm brake disc thickness for SB8.11 + SB17 series brakes (type NX)

Options

- Hubs ready bored and keywayed (preferably acc. to DIN 6885)
- Hubs with taper bore
- Hubs with double keyway
- Hubs with pilot bore
- Hubs in special dimensions
- Hubs with extension shafts (Ns)

Balancing grade ISO 1940 - G 6.3 is guaranteed for all coupling parts

Applications

All drives, where the brake is not located between motor and gearbox, like brake installation on the second gear box shaft or at the motor end shaft

Ordering Example

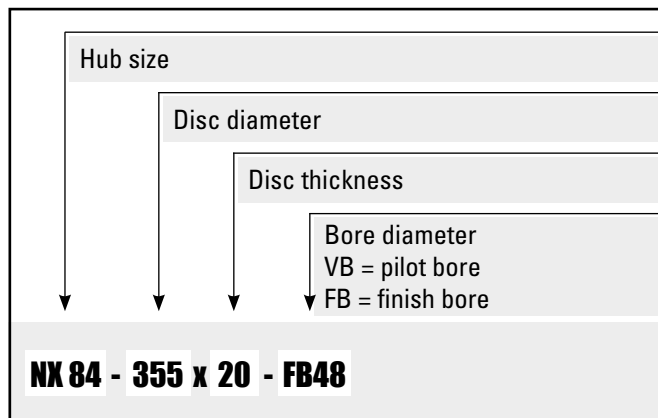

Ordering Example

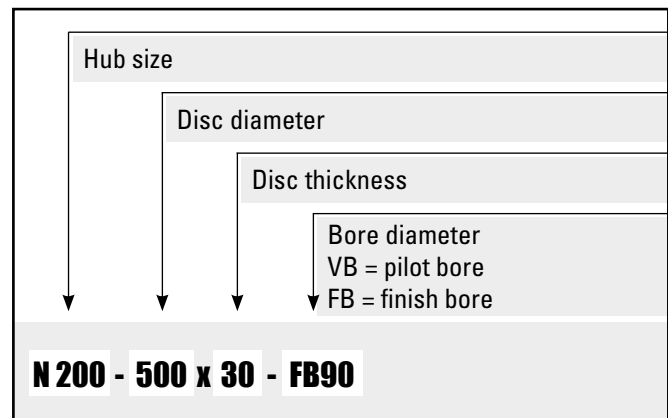

Please Note

We supply a detailed operating manual with every order. Hubs with brake discs are rotating parts and as such a cover must be fitted for the prevention of accidents.



PINTSCH BUBENZER Service

This includes the verification of the brake selection, if required. A detailed questionnaire is provided for this purpose. Installation and commissioning on-site by PINTSCH BUBENZER service engineers is possible. Drawings as DWG/DXF files for your engineering department are available upon request.

Hub with Brake Disc Type N

Dimensions and technical data



Rev. 12-06

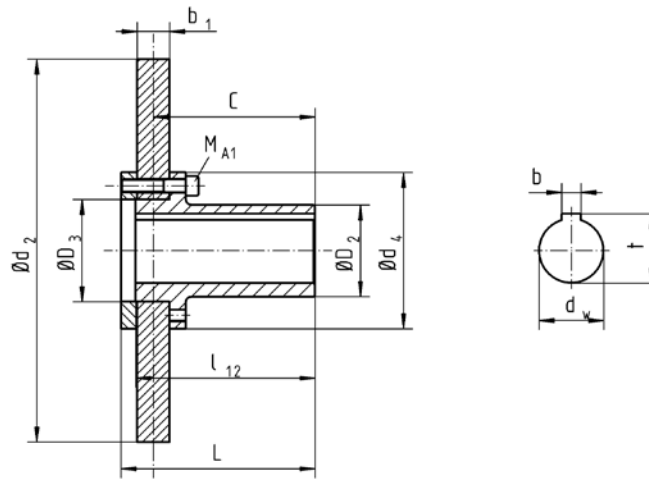

All dimensions in mm
Dimensions reserved without notice

Hub N (size = d4)		145	170	200	230	260	300	360	400
M _{Br} max.	Nm	1800	2850	4950	7740	11940	17550	29100	40050
n _{max} at max. disc Ø	min ⁻¹	3800	3400	3000	2700	2400	2200	1750	1750
d _w max.	mm	60	75	95	110	125	140	160	160
D ₂	mm	85	110	135	160	180	200	225	225
D ₃	mm	95	120	140	170	200	220	260	300
L	mm	180	180	220	220	230	230	275	275
l ₁₂	mm	166,5	166,5	207	207,5	212,5	212,5	252,5	252,5
C	mm	150	150	190	190	195	195	235*	235*
M _A	Nm	84	84	132	132	206	410	710	710
Brake disc diameter d ₂ x b ₁ (mm)	355 x 30	28			Weight			of the hub with	
		0,378			Moment of inertia			brake disc	
	400 x 30	35	37	44					kg
		0,603	0,612	0,653					kgm ²
	450 x 30	42	45	52					
		0,959	0,973	1,011					
	500 x 30		54	60	67	77			
			1,469	1,506	1,571	1,682			
	560 x 30			72	79	89			
				2,335	2,399	2,51			
630 x 30				95	105	109			
				3,768	3,879	4,081			
710 x 30					124	128			
					6,112	6,213			
800 x 30		Weights and moments of inertia are not binding, referring to the max. finish bore for the sizes 145 to 300 respectively for a finish bore of 120 mm for the sizes 360 and 400.				153	189		
900 x 30						9,808	10,456		
1000 x 30		* Dimension C = 230 mm at brake disc thickness 40 mm					221	232	
							16,123	16,473	
							257	267	
							24,075	24,424	

Hub with Brake Disc Type NX

Dimensions and technical data



Rev. 12-06

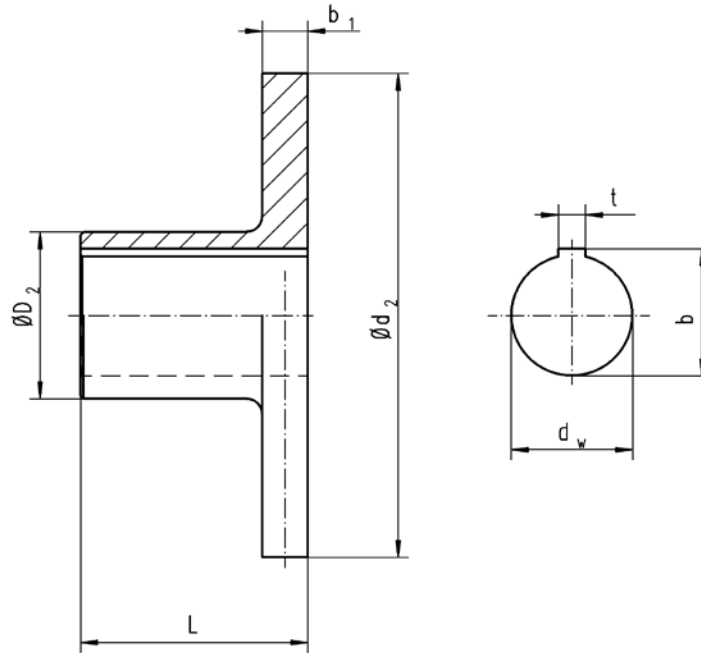

* Higher speeds possible by using sintered linings

All dimensions in mm
Alterations reserved without notice

Hub NX (size = D ₂)			58	64	74	84	92	100	114	
L mm			80	110	110	110	140	140	140	
d _w max. mm			38	42	48	55	60	65	70	
		n _{max.} min ⁻¹ *	Thermal capacity kW							
Brake disc diameter d ₂ x b ₁ (mm)	200 x 20	3500	344	5,6	6,2	Weight of the hub with brake disc				kg
				0,025	0,026	Moment of inertia				kgm ²
	225 x 20	3300	399	7,0	7,5	8,1	8,6	9,3	10,9	
				0,040	0,040	0,041	0,042	0,045	0,047	
	250 x 20	3000	474	8,5	9,0	9,6	10,1	10,8	12,4	14,0
				0,060	0,061	0,062	0,063	0,066	0,067	0,072
	280 x 20	2675	567	10,5	11,0	11,6	12,2	13,0	14,5	16,2
				0,095	0,096	0,096	0,097	0,100	0,102	0,107
	315 x 20	2380	653	13,2	13,7	14,3	14,9	15,5	17,1	18,7
				0,153	0,153	0,153	0,154	0,157	0,159	0,164
355x 20	2100	752		17,0	17,6	18,2	18,9	20,5	22,2	
				0,246	0,246	0,274	0,250	0,252	0,257	
400 x 20	1875	863		21,0	21,6	22,2	22,8	24,4	26,0	
				0,396	0,396	0,397	0,400	0,402	0,407	
450 x 20	1650	986			27,0	27,7	28,4	30,0	31,7	
					0,634	0,635	0,637	0,639	0,645	
500 x 20	1500	1100			33,0	33,7	34,4	36,0	37,7	
					0,956	0,966	0,969	0,970	0,976	

Flexible Coupling Type B-EBT + B-GBT

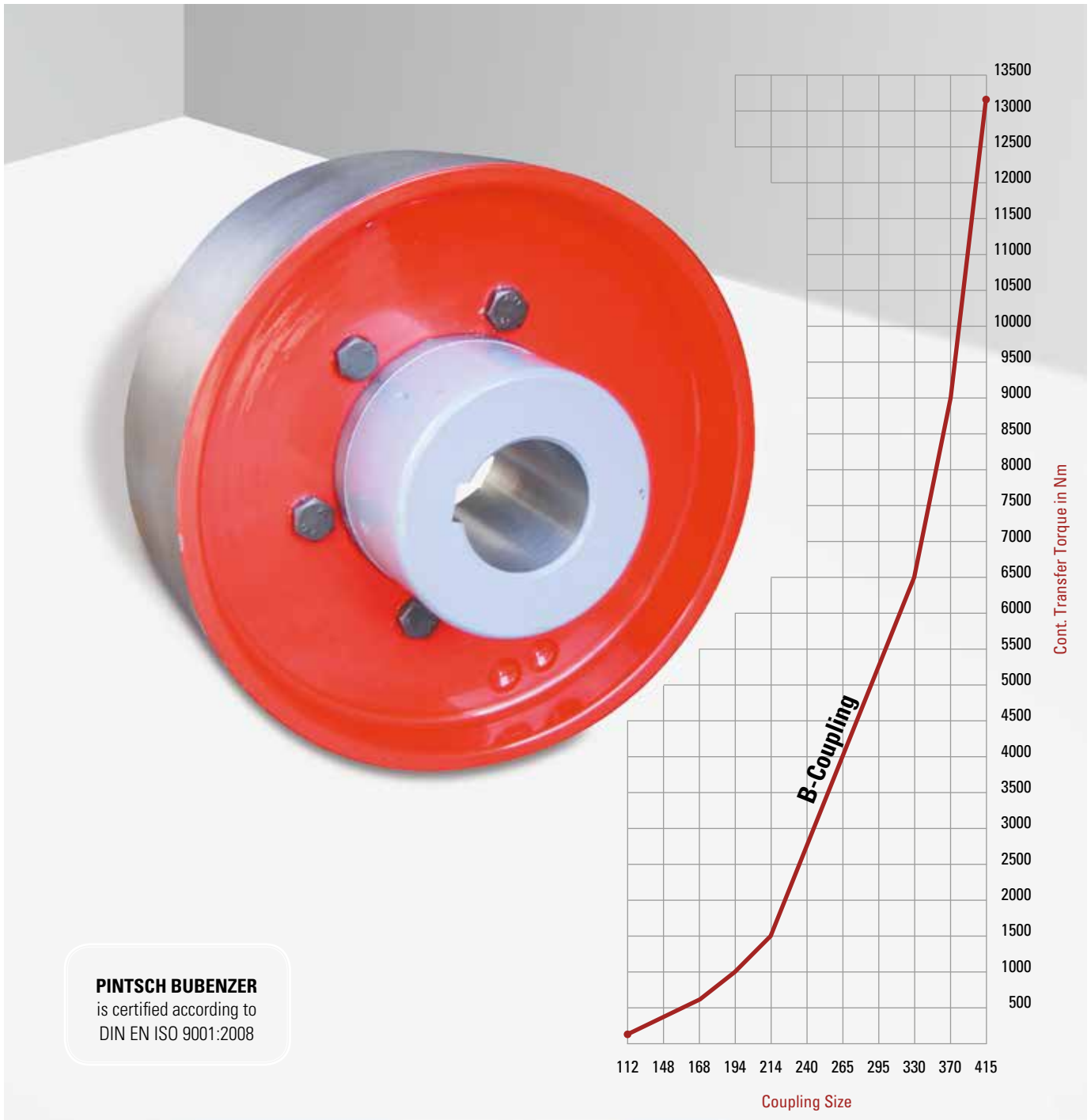

PINTSCH BUBENZER
is certified according to
DIN EN ISO 9001:2008



Torsionally Elastic



Tried and Trusted



High Performance



Robust



Easy Maintenance

Description Coupling Type B-EBT, B-GBT



Main Features

- Multi component GG / GGG flexible coupling
- Transmission of torque via elastic intermediate ring
- Replacement of the elastic intermediate ring without moving any equipment (B-GBT only)
- Installation of the brake drum on the load side to allow the brake torque to be maintained when the motor is disengaged
- Vast selection of coupling sizes and brake drum diameters to satisfy most braking and drive requirements

Options

- Coupling hubs ready bored and keywayed (acc. to DIN 6885)
- Coupling hubs with taper bore
- Coupling hubs with two keyway
- Coupling hubs with pilot bore
- Coupling balanced according to ISO 1940-Grade: G 6.3
- Special material for elastic intermediate ring depending on application
- Coupling without brake drum

Ordering Example

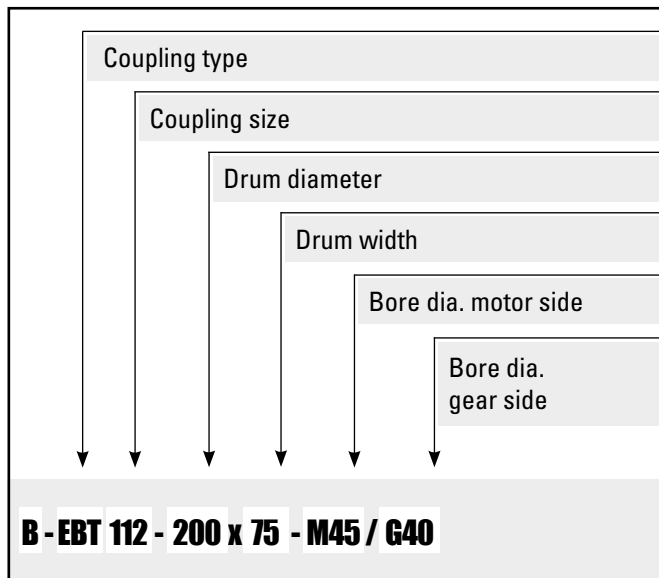

Applications

- These couplings are for use in machinery subjected to high dynamic load
- Damping of peak torques and vibrations are further reasons for the use of this coupling type
- The standard material of the elastic intermediate ring is suitable for a temperature range of -20°C...+80°C



Please Note

We supply a detailed operating manual with every order. Couplings are rotating parts and as such a cover must be fitted for the prevention of accidents.



PINTSCH BUBENZER Service

This includes the verification of the brake selection, if required. A detailed questionnaire is provided for this purpose. Installation and commissioning on-site by PINTSCH BUBENZER service engineers is possible. Drawings as DWG/DXF files for your engineering department are available upon request.

Flexible Coupling Type B-EBT

Dimensions and technical data



Rev. 12-06

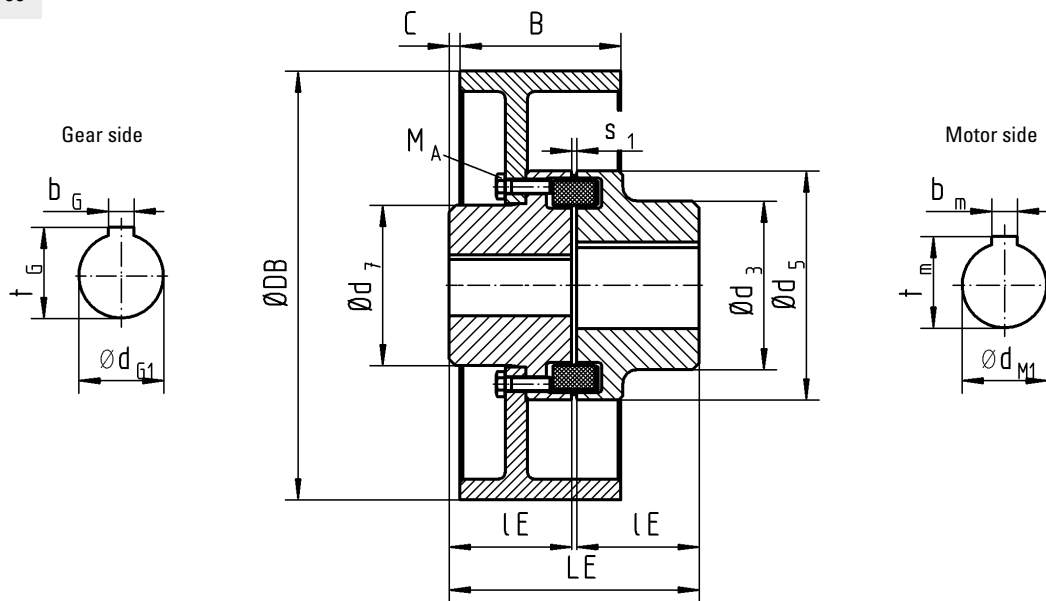

All dimensions in mm
Alterations reserved without notice

B-EBT (= d_5)		112	128	148	168	194	214	240	265	295	330	370	415
M_{Br} max.	Nm	450	550	1000	1600	2750	3350	4200	8700	9800	10600	13500	16000
T_{KN}	Nm	150	250	390	630	1050	1500	2400	3700	4900	6400	8900	13200
n_{max}	min ⁻¹	6000	5000	4500	4000	3500	3000	2750	2500	2250	2000	1750	1500
d_{M1} max.	mm	48	55	65	75	85	95	110	120	130	150	170	190
d_{G1} max.	mm	42	52	58	72	85	92	102	120	130	150	170	185
d_3	mm	79	90	107	124	140	157	179	198	214	248	278	315
d_7	mm	68	85	94	118	138	153	168	198	214	248	278	308
C	mm	11	16	16	*A	16,5	*B	*C	22	*D	*E	15	25
IE	mm	60	70	80	90	100	110	120	140	150	160	180	200
LE	mm	123,5	143,5	163,5	183,5	203,5	224	244	285,5	308	328	368	408
S_2	mm	3,5±1	3,5±1	3,5±1	3,5±1,5	3,5±1,5	4±2	4±2	5,5±2,5	8±2,5	8±2,5	8±2,5	8±2,5
M_A	Nm	25	25	49	49	85	85	85	210	210	210	210	210
Brake drum diameter DB x B (mm)	200 x 75	9,1	12,3						Weight		of the coupling		kg
		0,038	0,044						Moment of inertia		with brake drum		kgm ²
	250 x 95			20,2	26,4								
				0,116	0,14								
	315 x 118				32,9	40,4	49,2						
					0,3511	0,39	0,45						
	400 x 150						63,4	72,6					
							1,056	1,145					
500 x 190							96,6	116,8	133,9				
							2,795	2,99	3,3				
630 x 236									192,9	236,5			
									8,67	9,15			
710 x 265											264,5	313,8	381,1
											15,26	16,22	17,77

*A Dimension C = 19 mm at δ 250 mm, 8 mm at δ 315 mm
 *B Dimension C = 19 mm at δ 315 mm, 12,5 mm at δ 400 mm
 *C Dimension C = 18 mm at δ 400 mm, 9 mm at δ 500 mm
 *D Dimension C = 30 mm at δ 500 mm, 5 mm at δ 630 mm
 *E Dimension C = 11 mm at δ 630 mm, 0 mm at δ 710 mm

Flexible Coupling Type B-GBT

Dimensions and technical data



Rev. 12-09

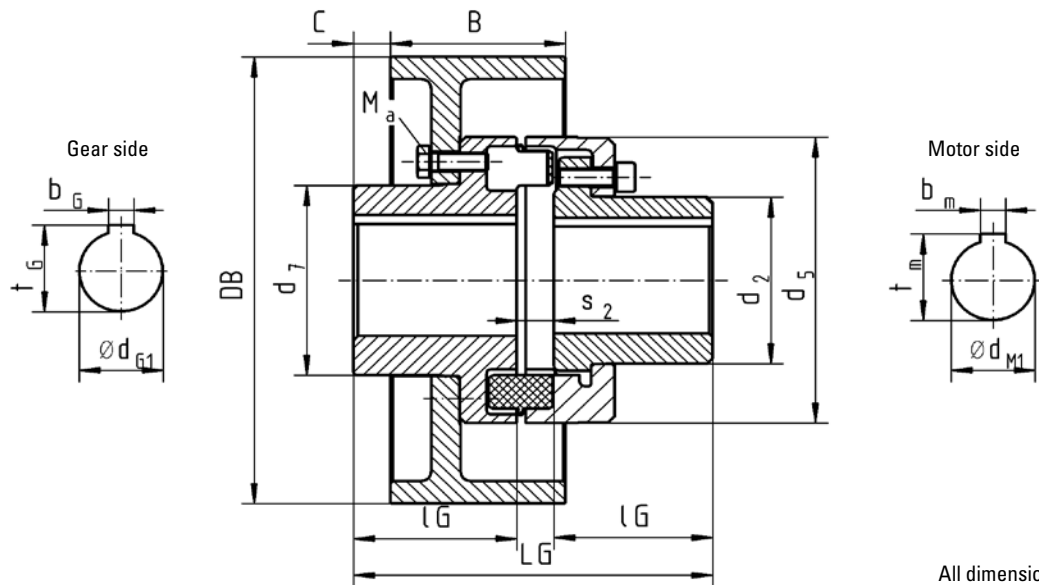

All dimensions in mm
Alterations reserved without notice

B-GBT (= d ₅)		112	128	148	168	194	214	240	265	295	330	370	415
M _{Br} max.	Nm	450	550	1000	1600	2750	3350	4200	8700	9800	10600	13500	16000
T _{KN}	Nm	150	250	390	630	1050	1500	2400	3700	4900	6400	8900	13200
n _{max}	min ⁻¹	6000	5000	4500	4000	3500	3000	2750	2500	2250	2000	1750	1500
d _{M1} max.	mm	46	53	65	75	85	95	100	115	130	135	160	180
d _{G1} max.	mm	42	52	58	72	85	92	102	120	130	150	170	185
d ₂	mm	64,5	74,5	92,5	104,5	121,5	135,5	146	164	181	208	241	275
d ₇	mm	68	85	94	118	138	153	168	198	214	248	278	308
C	mm	11	16	16	*A	16,5	*B	*C	22	*D	*E	15	25
l _G	mm	58	68	78	87	97	107	117	137	147	156	176	296
l _G	mm	133	154	176	198	221	243	267	310	334	356	399	441
S ₂	mm	15±1	16±1	18±1	21±1,5	24±1,5	26±2	30±2	33±2	37±2,5	40±2,5	43±2,5	45±2,5
M _A	Nm	25	25	49	49	85	85	85	210	210	210	210	210
Brake drum diameter DB x B (mm)	200 x 75	9,1	12,4					Weight		of the coupling			kg
		0,038	0,045					Moment of inertia		with brake drum			kgm ²
	250 x 95			20,2	26,4								
				0,12	0,15								
	315 x 118				32,9	40,9	49,2						
					0,353	0,396	0,46						
	400 x 150						63,4	71,7					
							1,065	1,157					
500 x 190							95,7	115,9	133,7				
							2,807	3,014	3,26				
630 x 236									192,7	233,1			
710 x 265										8,63	9,183		
											261,1	310,8	379,5
											15,29	16,28	17,9

Brake Drums acc. to DIN 15431

Dimensions and technical data



Rev. 05-08

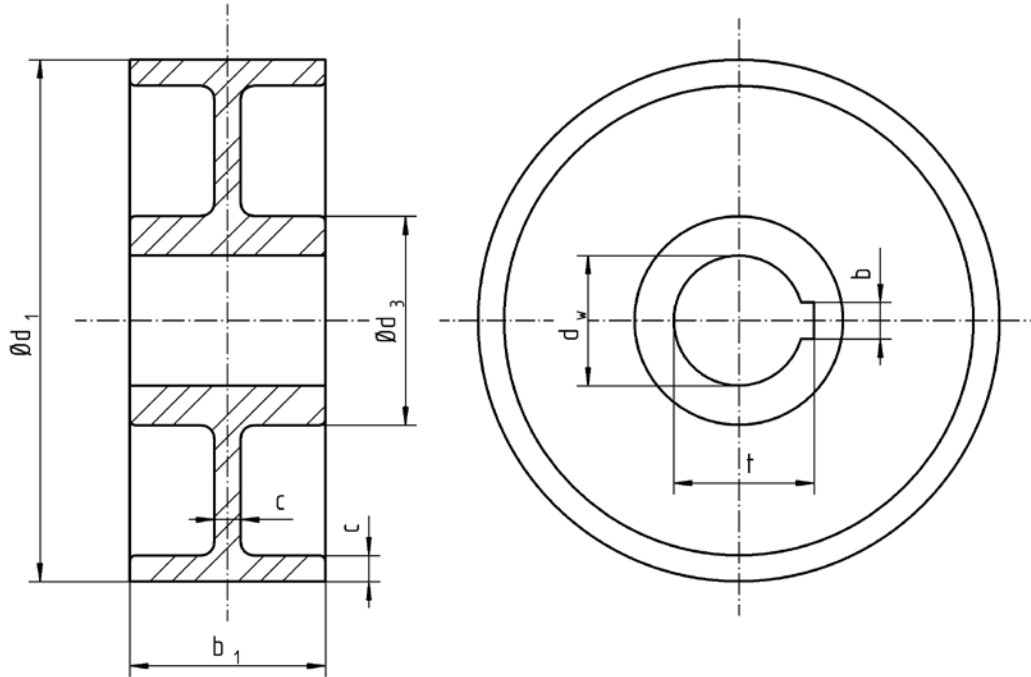

Material options:	GG25
	GGG40
	St 52 welded
	C45
When ordering please indicate:	Brake drum $\varnothing d_1$
	Material
	Bore $\varnothing d_2$

All dimensions in mm
Alterations reserved without notice

d_1	b_1	c	d_2		d_3	Moment of inertia J kgm ²	Weight kg (GGG)	Nominal heat capacity W_{n150} (kJ)		
			pilot bored	max. ready bored				St/GS	GG	GGG
200	75	10	20	50	80	0,039	7,4	264	273	371
250	95	12	25	60	95	0,1156	13,7	502	519	707
315	118	15	30	80	115	0,3585	26,4	982	1016	1383
400	150	17	35	90	130	1,0687	47,3	1806	1869	2544
500	190	20	50	100	150	3,1162	85,3	3374	3490	4751
630	236	25	50	110	170	9,6564	161,7	6602	6831	9217
710	265	30	70	120	200	18,4627	243,1	9999	10345	14080



The brake drums can be balanced on request if ordered ready bored and keywayed. If requested, brake drums can be made according to customer specifications.

Monitoring System VSR2-SB



PINTSCH BUBENZER
is certified according to
DIN EN ISO 9001:2008

Supply
115/230 VAC

Visual indication of			
thruster stroke < 5 mm > 20 mm < 55 mm	maximum brake pad temperature	air gap difference between disc and pad surface by measuring the temperature difference between pads caused by unilateral pad rubbing	pad thickness < 5 mm

Description VSR2-SB



In response to requirements to simplify the maintenance of industrial brakes and at the same time to increase their operational safety, PINTSCH BUBENZER offers a retrofitable, compact electronic status indication system to be integrated into the brake as an additional safety device

Main Features

Industrial display with 4 rows of 20 characters for indication of measurement data and error messages

High ambient temperature range – 20°C.....+70°C

Protection class IP66

Internal keypad for parameter change

Up to 5 m cable length from sensor to electronic box. (Option)

Brake operation cycle counter (up to 100 Mio. Cycles)

Supply voltage selection switch 115/230 V AC

One common error relay contact (VSR2-SB only)

Option RPM speed sensor available

Option: Stainless steel electronic box IP66 for outdoor use

Parts for VSR2-SB

Supply voltage: The electronic unit can be connected directly to 110-240 VAC supply voltage. The internal voltage selector switch must be set by the user to the corresponding position 115 or 230 V

Temperature sensor: A pair of Pt100 sensors (B) measures the temperature of the each brake pad. If the temperature is too high or if the temperature is unequal from left to right side the unit generates a signal that is displayed in the panel. This reflected to the main control plc if the CMB2-SB unit is added

Pad wear sensor: If the minimum brake pad thickness is reached, the sensors (A) send a signal to the electronic box

Display: All measured analogue and digital signals and error messages are shown on the display in English language. Other languages are available on request. The display is readable under direct sunshine and has a LED backlight for use in a dark environment, such as steel mills.

Keypad: With the internal key pad, the user can adjust parameters such as changing the temperature display from Celsius (°C) to Fahrenheit (°F) or setting of the Profibus address

Reset button: The LED pushbutton on top of the electronic box indicates a wrong brake adjustment by a flashing red light. After the problem on the brake is solved, the status of the VSR2-SB / CMB2-SB can be reset to normal operation by pushing the button.

Proximity switch release control: This switch and the optional manual release switch are independent from the VSR2-SB/ CMB2-SB and have to be connected to the control plc

Stroke sensor: A digital stroke sensor detects an Eldro reserve stroke <5mm or larger than 15 mm

Relay contact: A dry contact (max 250 V 2 A) is connected to terminals 21/22. It is closed in normal status of the VSR2-SB and open, if the system is in error mode, or switched off

Monitoring System VSR2-SB

Dimensions and technical data



Rev. 05-16

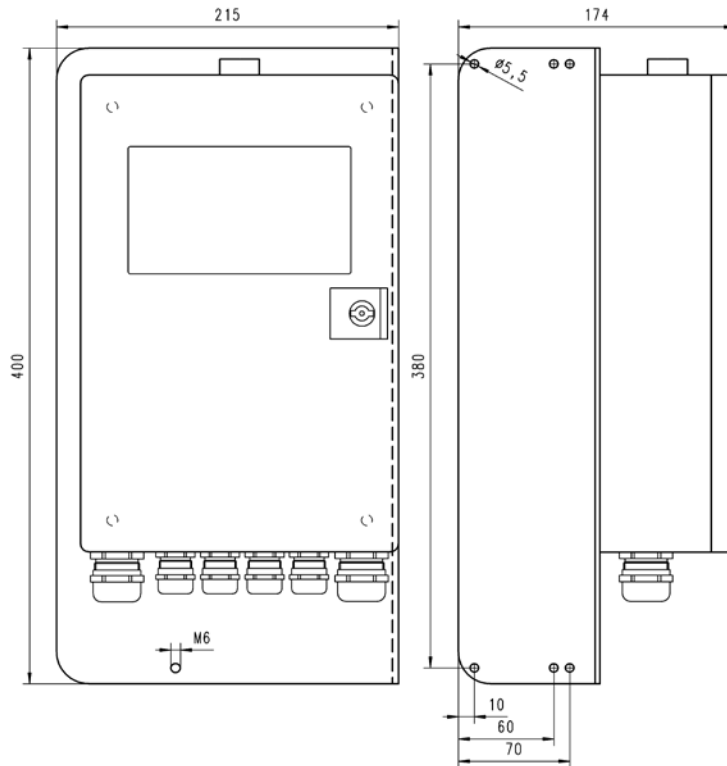

Cable glands wired by PB:

- M25: Padwear1, Padwear2, Stroke, Force
- M12: Temperature 1
- M20: Release, Manual Release
- M20: Speed, Temperature 2
- M12: spare

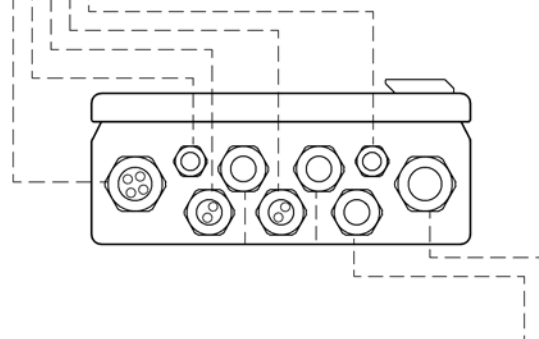

Cable glands for customer:

- M20: Supply voltage, max cable diameter 13 mm
- M25: Signals to crane, max cable diameter 17 mm

Remark: Force, Profibus In and Out only for CMB2

Monitoring System VSR2-SB

Dimensions and technical data



Rev. 05-16

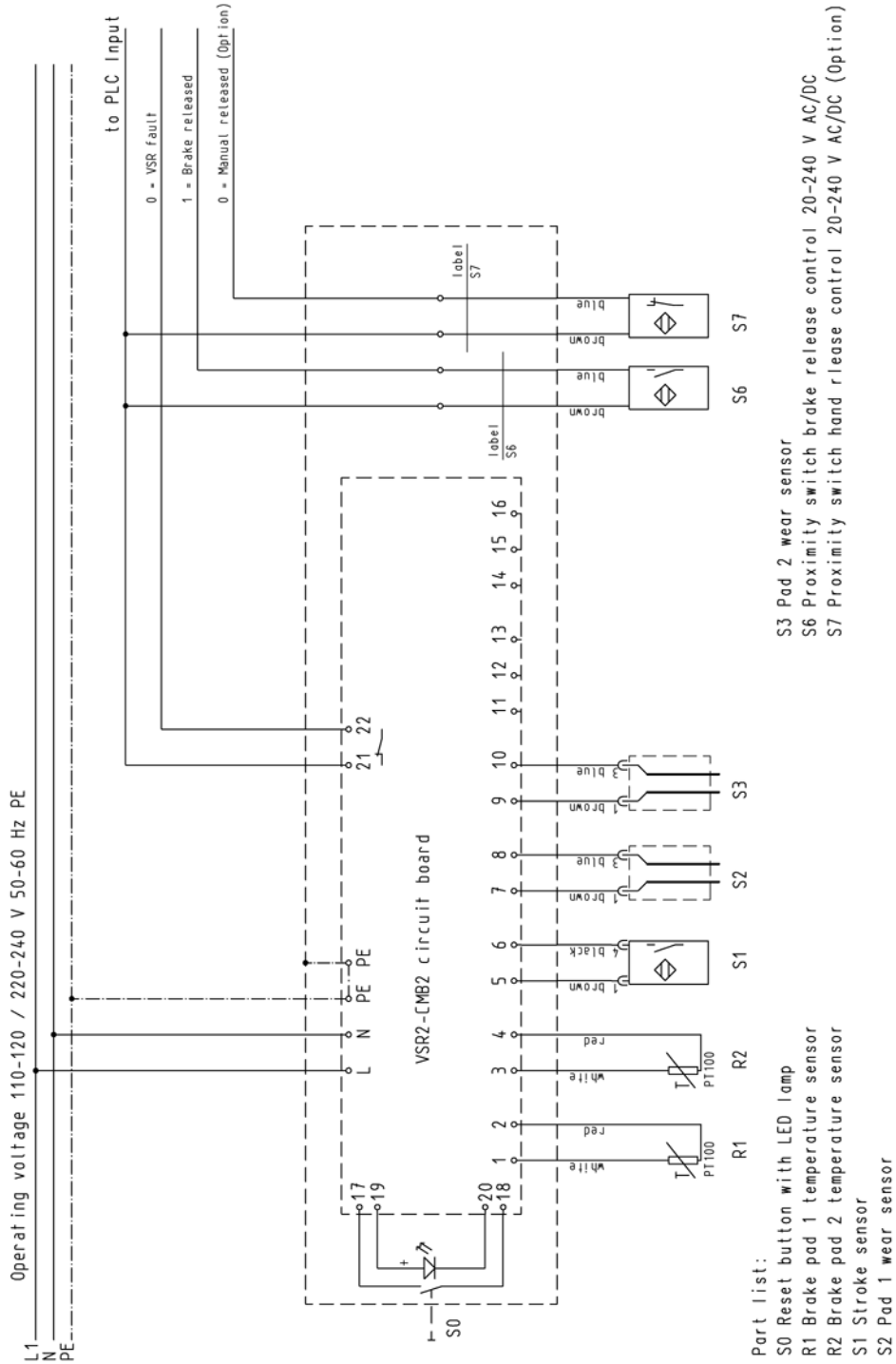

Brake Control System BB 900

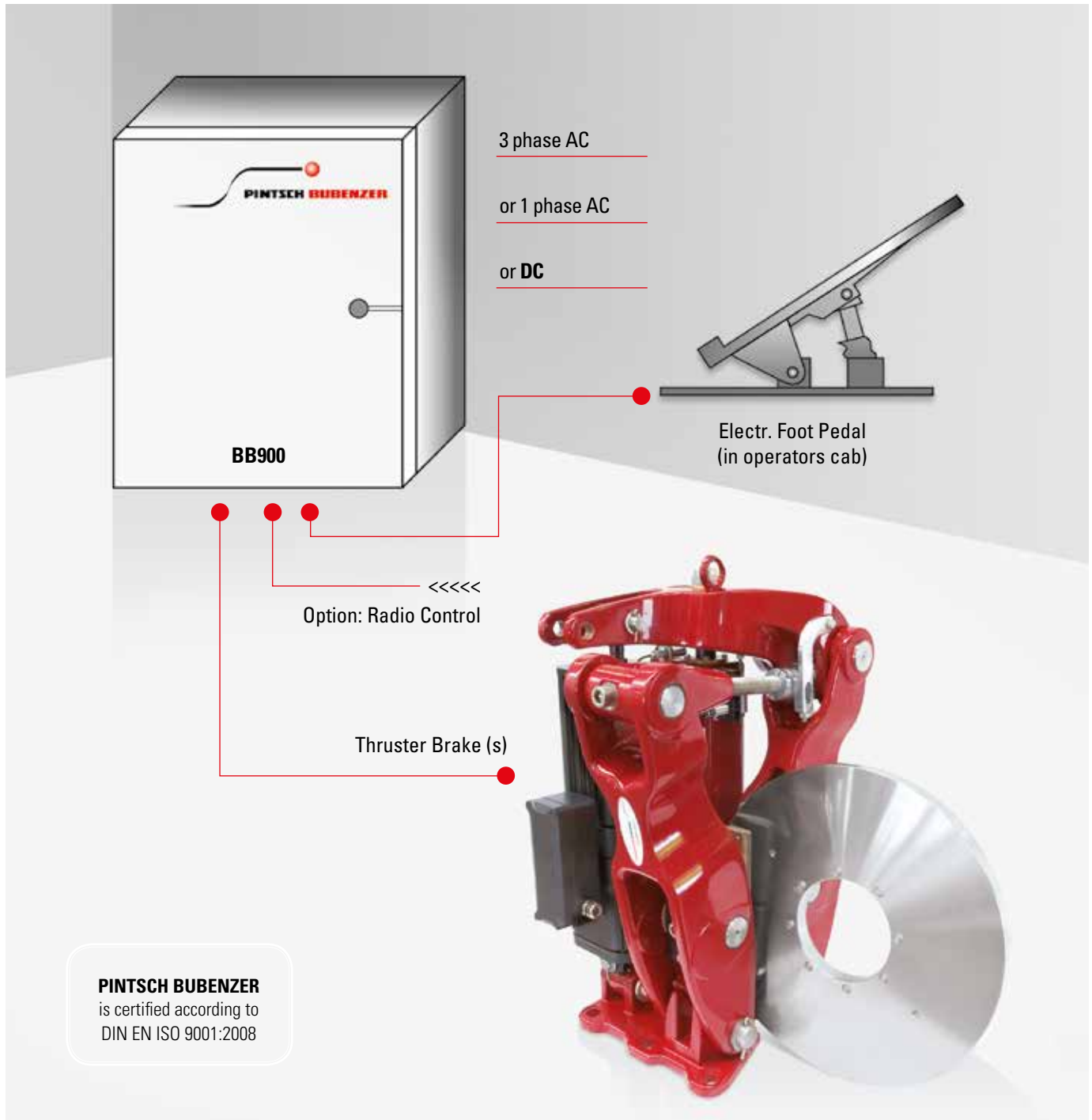

Controlled Braking



Simple Installation



Retrofitable



Brake Remains Failsafe!



Use of AC Thrusters in DC Systems!

Description BB 900



Version 0

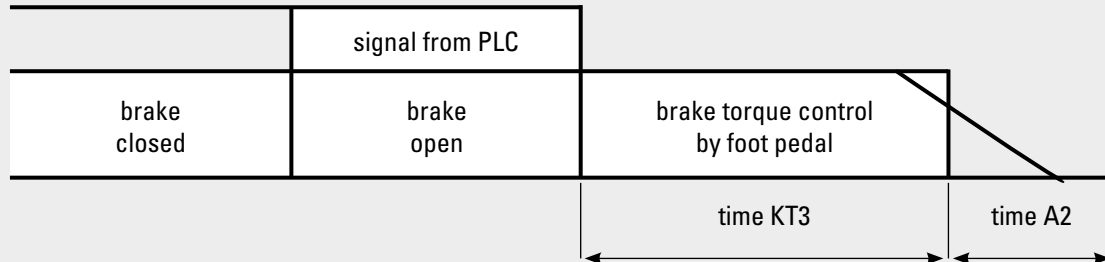

Version 1

Foot pedal with two limit switches. Actuation of the foot pedal switches off the drive motor and allows braking control with the pedal. When the pedal is depressed to the full extent, the brake remains closed until the customer's master switch is actuated once more.

Version 2

Two operating modes, accessed by the customer's selector switch.

1. Direct opening and closing of the brake without time delay.
2. Direct opening of the brake; Closing of the brake with adjustable time delay. During this time delay, braking can be carried out by the foot pedal.

Version 3

Customer's current (4...20 mA) or voltage signal (0...10 V) for the stepless control of the brake torque (without foot pedal)

All frequency converter units as standard with:

Steel enclosure for use under harsh environmental conditions (600x600x210mm).

Main power input filter for filtering out main disturbances.

Filter for reducing voltage spikes of the electro-hydraulic brake thrusters and eliminating EMV problems.

Board for connection of the standard PINTSCH BUBENZER foot pedal with inductive coil.

Ordering Example

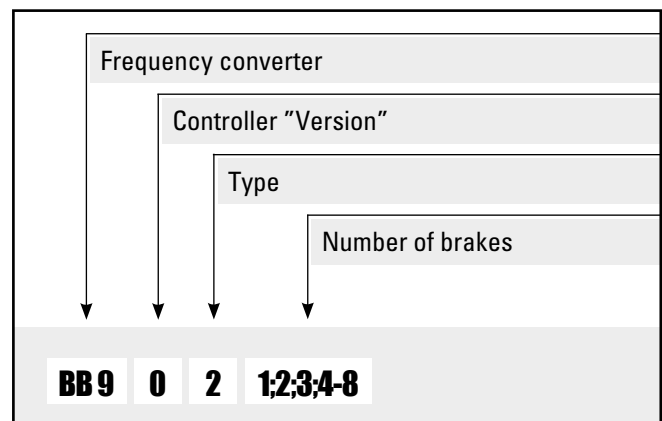

Foot Pedal

for electric operated brakes



Rev. 09-02

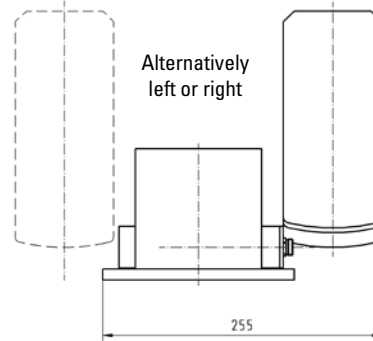
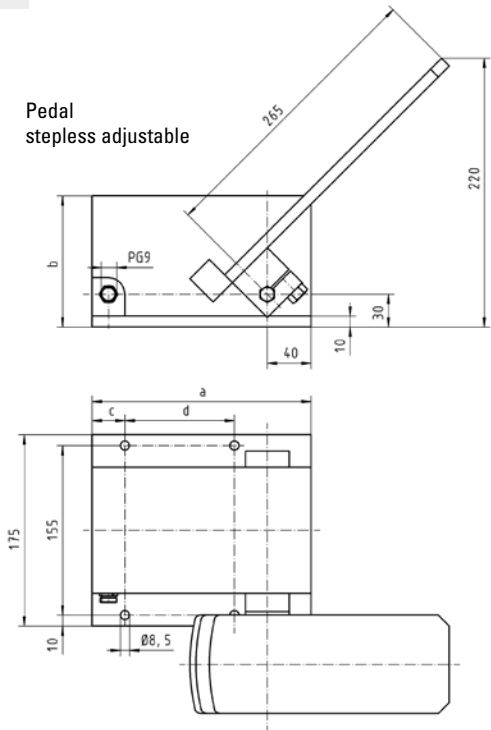

Electr. Foot Pedal "A"
for installation on top cabin floor

Execution	a	b	c	d	Weight kg.
Foot pedal "A" for max. 2 brakes	200	120	30	100	7,8
Double foot pedal "A" for max. 4 brakes	275	135	33	175	9,2

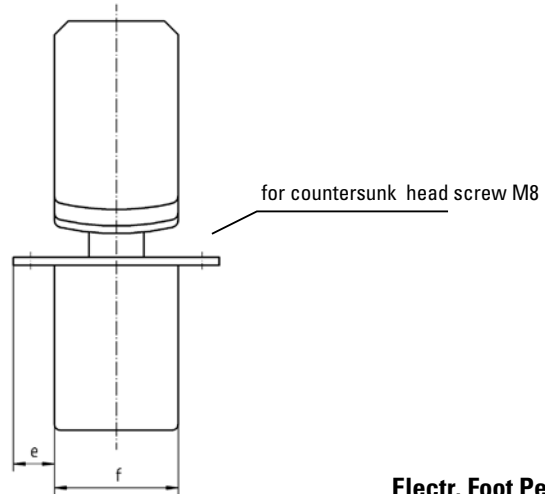
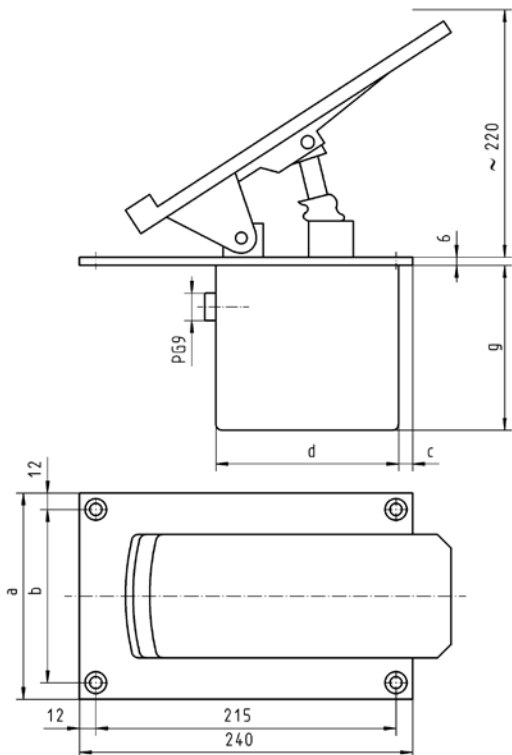

Electr. Foot Pedal "B"
for installation into the cabin floor

Execution	a	b	c	d	e	f	g	Weight kg.
Foot pedal "B" for max. 2 brakes	150	125	10	135	25	85	95	4,7
Double foot pedal "B" for max. 4 brakes	224	195	25	145	22	180	105	6,8

Monitoring System CMB-3



PINTSCH BUBENZER
is certified according to
DIN EN ISO 9001:2008

Permanent monitoring of



Thruster Stroke



Contact Force Brake Force



Lining Temperature



Lining Wear

Description CMB-3



Main Features

■	Profibus or Profinet bus system possible
■	Automatic power supply range switch 110-240 V AC
■	One CMB-3 box can handle up to
■	2 brakes SB28 / SB23 / SB16
■	2 brakes SF10...SF40
■	1 dual caliper brake SF50
■	Cable for sensors have a plug M12 on each end for easy troubleshooting
■	Same type of box for SF and SB brake types
■	Industrial display with 4 rows of 20 characters for indication of measurement data and error messages
■	High ambient temperature range -20°C.....+70°C
■	Protection class IP65
■	Internal keypad for parameter change
■	Up to 20 m cable length from sensor to electronic box (Option).
■	Brake operation cycle counter (up to 100 million Cycles)
■	One common error relay contact
■	Profibus / Profinet: All scaled measures signals and error bits are transferred by bus system to the main control PLC. No expensive analogue inputs are required in control PLC

Options

■	Stainless steel electronic box IP66
■	Sunshine protection cover for outdoor use



Please Note

We supply a detailed operating manual with every order. Couplings are rotating parts and as such a cover must be fitted for the prevention of accidents.



PINTSCH BUBENZER Service

This includes the verification of the brake selection, if required. A detailed questionnaire is provided for this purpose. Installation and commissioning on-site by PINTSCH BUBENZER service engineers is possible. Drawings as DWG/DXF files for your engineering department are available upon request.

Monitoring System CMB-3

Dimensions and technical data



Rev. 06-16

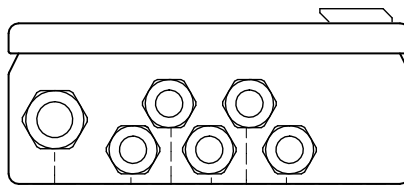
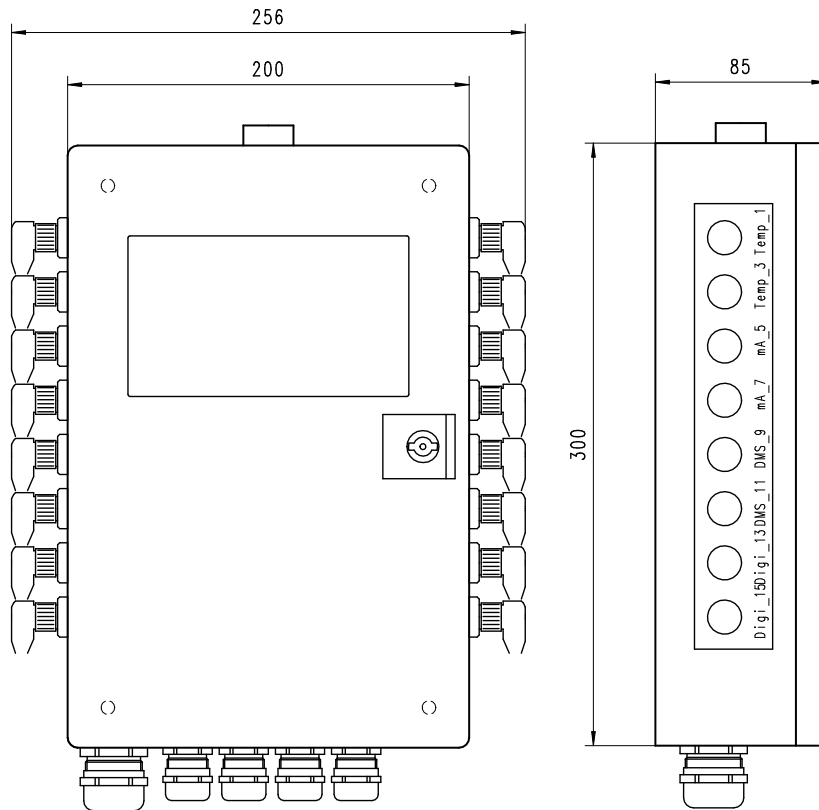

Cable glands free for customer:

M25: Profinet, Max cable diameter 17 mm

M20: Signals to crane, max cable diameter 13 mm

M20: Profibus In, max cable diameter 17 mm

M20: spare

M20: Profibus Out, max cable diameter 13 mm

M20: Supply voltage, max cable diameter 13 mm

Monitoring System CMB-3 for SB Brakes

Dimensions and technical data



Rev. 06-16

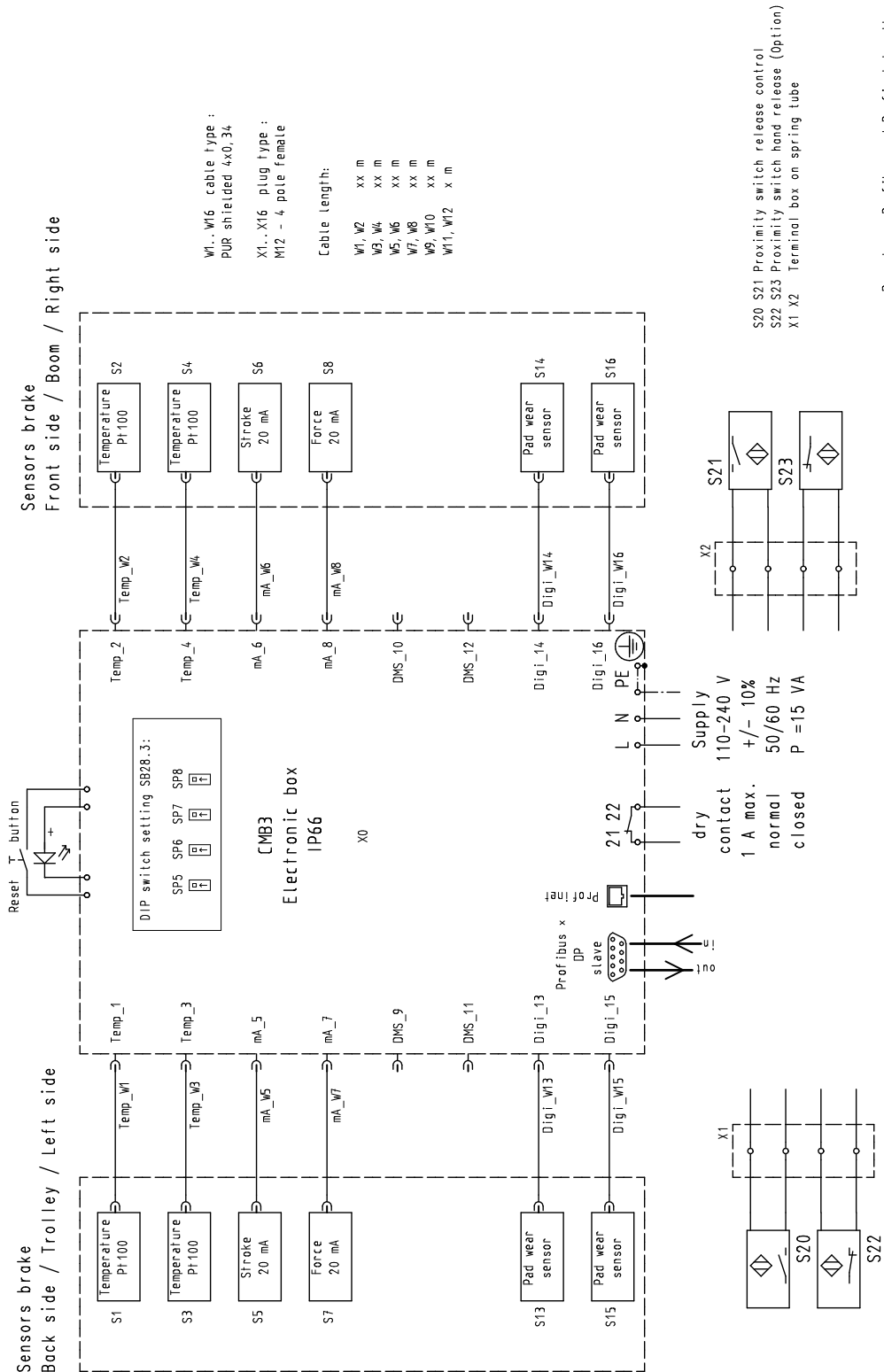

Monitoring System CMB-3 for SF Brakes

Dimensions and technical data



Rev. 06-16

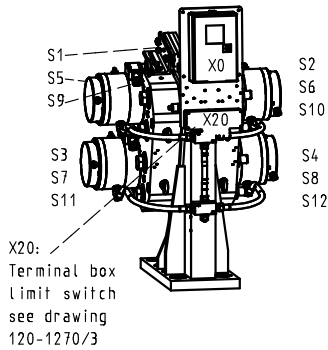
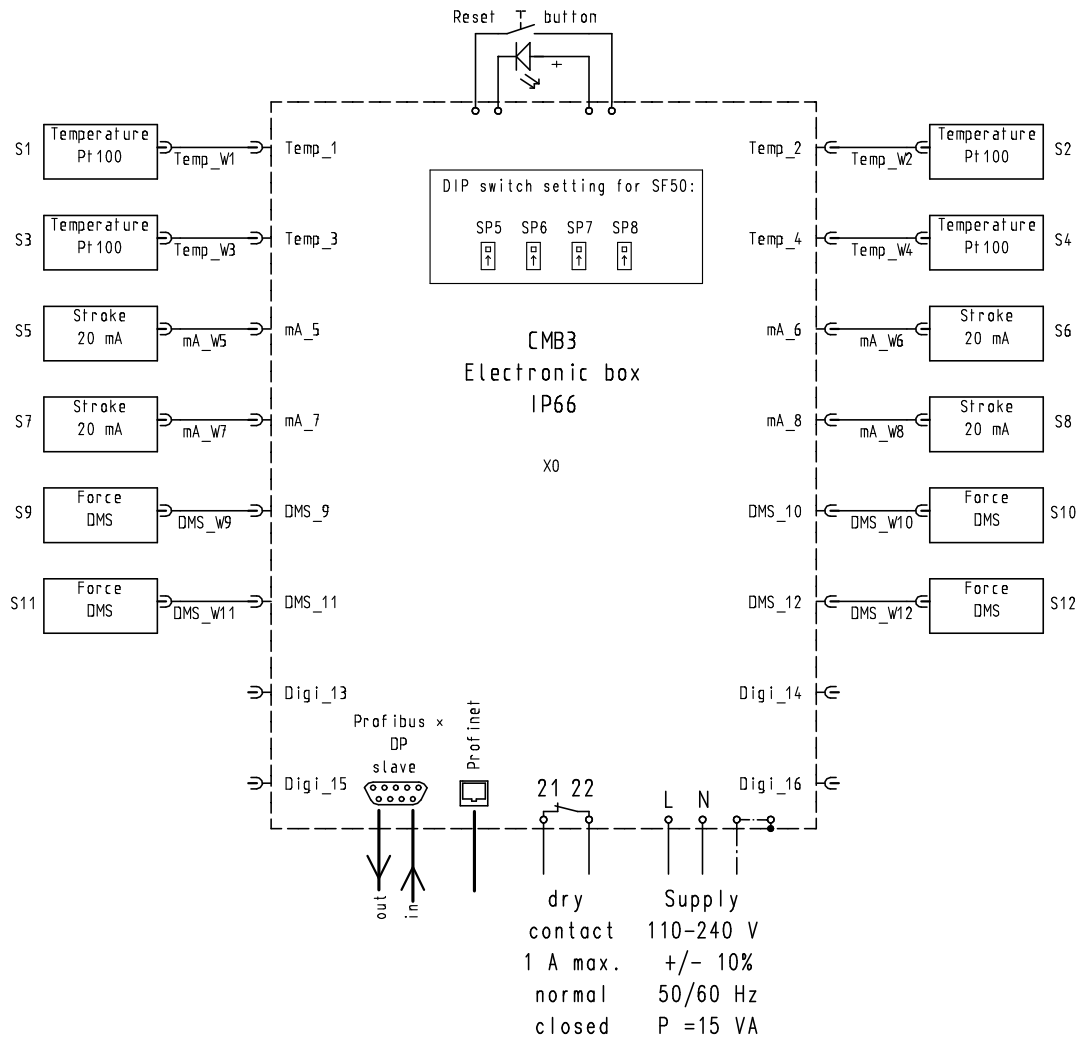

* Do not use Profibus and Profinet together

W1..W16 cable type :
PUR shielded 4x0,34

X1..X16 plug type :
M12 - 4 pole female

Cable length:

W1, W2	1,2 m
W3, W4	1,5 m
W5, W6	1,2 m
W7, W8	1,5 m
W9, W10	1,0 m
W11, W12	1,3 m

Rail Clamps Type BSZ



PINTSCH BUBENZER
is certified according to
DIN EN ISO 9001:2008



Safe



Tried and Trusted



High Performance



Robust



Easy Maintenance

Description BSZ



Main Features

■	Rail clamp spring applied
■	Apply time: Continuously adjustable 3-12 seconds
■	Rail clamp hydraulically released
■	Hand pump for emergency release
■	Integrated hydraulic power unit, ready piped and wired to terminal box
■	Limit switch release control, mechanical or proximity type
■	Connection by flange on end face (BSZ/II)
■	Connection by flange on top (BSZ/III)
■	Static applications
■	Holding forces 100-400 kN
■	Lateral compensation ± 10 mm

Options

■	Special mounting dimensions
■	Holding forces up to 1000 kN
■	Lateral compensation ± 25 mm
■	Vertical compensation ± 25 mm
■	Buffer connection
■	Rail sweeper
■	Operation of several rail clamps by one hydraulic power unit
■	Enclosures of stainless steel

Ordering Example

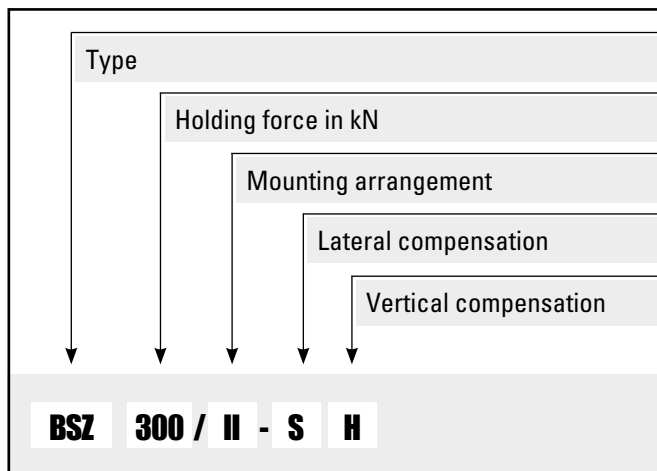

Applications

As storm brake on all rail mounted equipment, e. g. cranes, stackers, reclaimers etc. Particularly when the rail is mounted above dock level or a rail channel is provided

Operating Restrictions

Rail clamps of this range are tested both mechanically and hydraulically and are set to nominal force. This setting can only be changed by the manufacturer. Operating conditions other than described in this brochure require the manufacturer's approval and may influence the function of the rail clamp and its components



Please Note

We supply a detailed operating manual with every order. Nevertheless, we would point out that rail clamps are only as safe as the servicing and maintenance performed while they are in operation. The guarantee for the correct functioning of our rail clamps is therefore only valid if the user adheres to the German DIN standard 15019 part 1, table 5. Do not use rail clamps as dynamic brakes.



PINTSCH BUBENZER Service

This includes the installation and commissioning on site by PINTSCH BUBENZER service engineers, if required. Drawings as DWG/DXF files for your engineering department are available upon request.

Rail Clamp BSZ/II

Dimensions and technical data



Rev. 10-08

Connection in combination with a flange on the end face

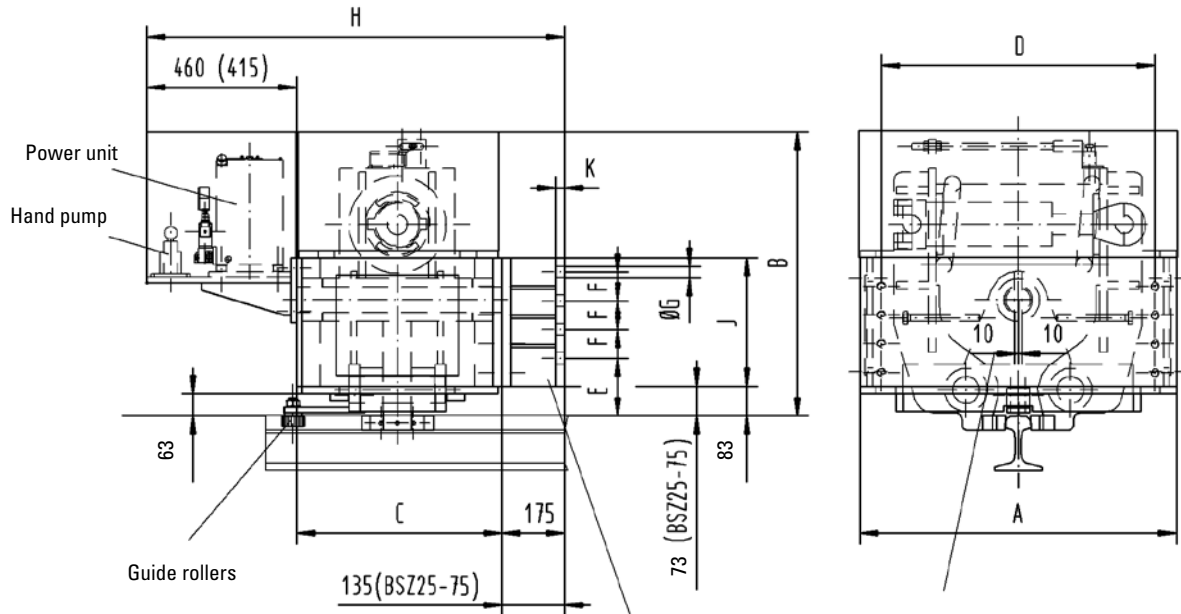

Lateral compensation ± 10 mm

Dimensions D,E,F,G,n and J by customer data or by table

n = Quantity of fixing holes

Holding force

All dimensions in mm
Alterations reserved without notice

Type	kN	A	B	C	D	E	F	G	H	J	n	K
BSZ 25/II	25	650	745	295	500	120	105	17	820	305	6	15
BSZ 50/II	50	650	745	295	500	120	105	21	820	305	6	20
BSZ 75/II	75	650	745	295	500	120	105	21	820	305	6	20
BSZ 80/II	80	690	755	470	500	133	100	21	1060	415	8	25
BSZ 100/II	100	690	755	470	500	133	100	26	1060	415	8	25
BSZ 120/II	120	690	755	470	500	133	100	26	1060	415	8	25
BSZ 140/II	140	690	755	470	500	133	100	30	1060	415	8	25
BSZ 150/II	150	880	790	575	800	120	90	30	1170	358	8	25
BSZ 200/II	200	880	790	575	800	120	90	33	1210	358	8	25
BSZ 250/II	250	880	790	575	800	120	90	33	1210	358	8	25
BSZ 300/II	300	880	790	575	800	120	90	33	1210	358	8	25
BSZ 400/II	400	880	790	575	800	120	90	33	1210	358	8	25

Rail Clamp BSZ/II-SH

Dimensions and technical data



Rev. 10-08

Connection in combination with a flange on the end face

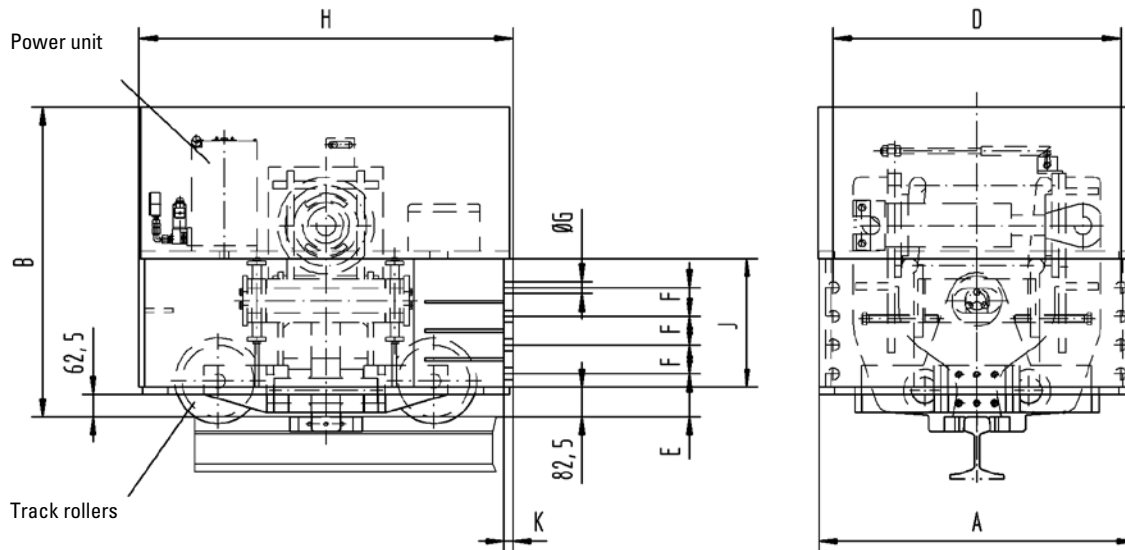

Vertical compensation ± 25 mm
Lateral compensation ± 25 mm

Dimensions D, E, F, G, n and J
by customer data or by table

n = Quantity of fixing holes
m = ca. weight in kg

All dimensions in mm
Alterations reserved without notice

Type	Holding force kN	A	B	D	E	F	G	H	J	n	K	m
BSZ 80/II	80	880	865	800	120	80	26	1040	368	8	25	780
BSZ 100/II	100	880	865	800	120	80	26	1040	368	8	25	820
BSZ 120/II	120	880	865	800	120	80	30	1040	368	8	25	830
BSZ 140/II	140	880	865	800	120	80	30	1040	368	8	25	830
BSZ 150/II	150	880	910	800	120	90	33	1115	368	8	25	1000
BSZ 200/II	200	880	910	800	120	90	33	1115	368	8	25	1060
BSZ 250/II	250	880	910	800	120	90	33	1115	368	8	25	1060
BSZ 300/II	300	880	910	800	120	90	33	1115	368	8	25	1060
BSZ 400/II	400	880	910	800	120	90	33	1115	368	8	25	1100

Rail Clamp BSZ/III

Dimensions and technical data



Rev. 10-08

Connection in combination with a flange on top

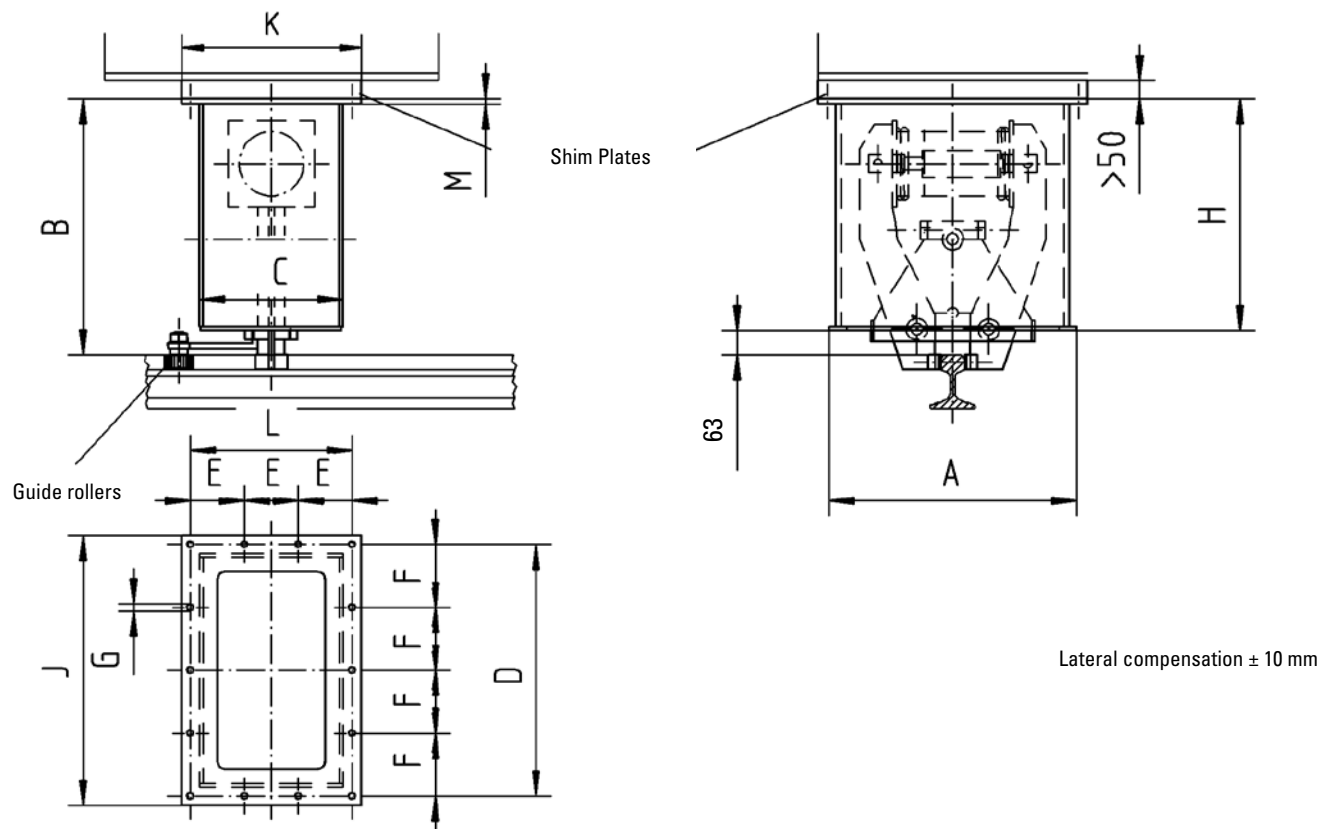

Type	Holding force kN	All dimensions in mm Alterations reserved without notice											
		A	B	C	D	E	F	G	H	J	K	L	M
BSZ 25/III	25	640	698	390	700	150	175	22	635	750	500	450	20
BSZ 50/III	50	640	698	390	700	150	175	22	635	750	500	450	20
BSZ 75/III	75	640	698	390	700	150	175	22	635	750	500	450	20
BSZ 80/III	80	600	750	600	660	100	110	26	687	720	660	600	20
BSZ 100/III	100	600	750	600	660	100	110	26	687	720	660	600	20
BSZ 120/III	120	600	750	600	660	100	110	26	687	720	660	600	25
BSZ 140/III	140	600	750	600	660	100	110	26	687	720	660	600	25
BSZ 150/III	150	900	823	720	950	162	190	26	760	1040	900	810	30
BSZ 200/III	200	900	823	720	950	162	190	26	760	1040	900	810	30
BSZ 250/III	250	900	823	720	950	162	190	26	760	1040	900	810	30
BSZ 300/III	300	900	823	720	950	162	190	26	760	1040	900	810	30
BSZ 400/III	400	900	823	720	950	162	190	26	760	1040	900	810	30

Rail Clamp BSZ

Hydraulic diagram



Rev. 09-02

Q:	4,25 l/min (50 Hz) 5,1 l/min (60 Hz)
p:	250 bar (50Hz) 210 bar (60Hz)
P:	1,1 kW (50 Hz) 1,3 kW (60Hz)
Control voltage:	24 V DC 110 V AC 230 V AC
Supply voltage:	360-440 V AC (50Hz) 380-480 V AC (60Hz)
Tank capacity:	5 Litres

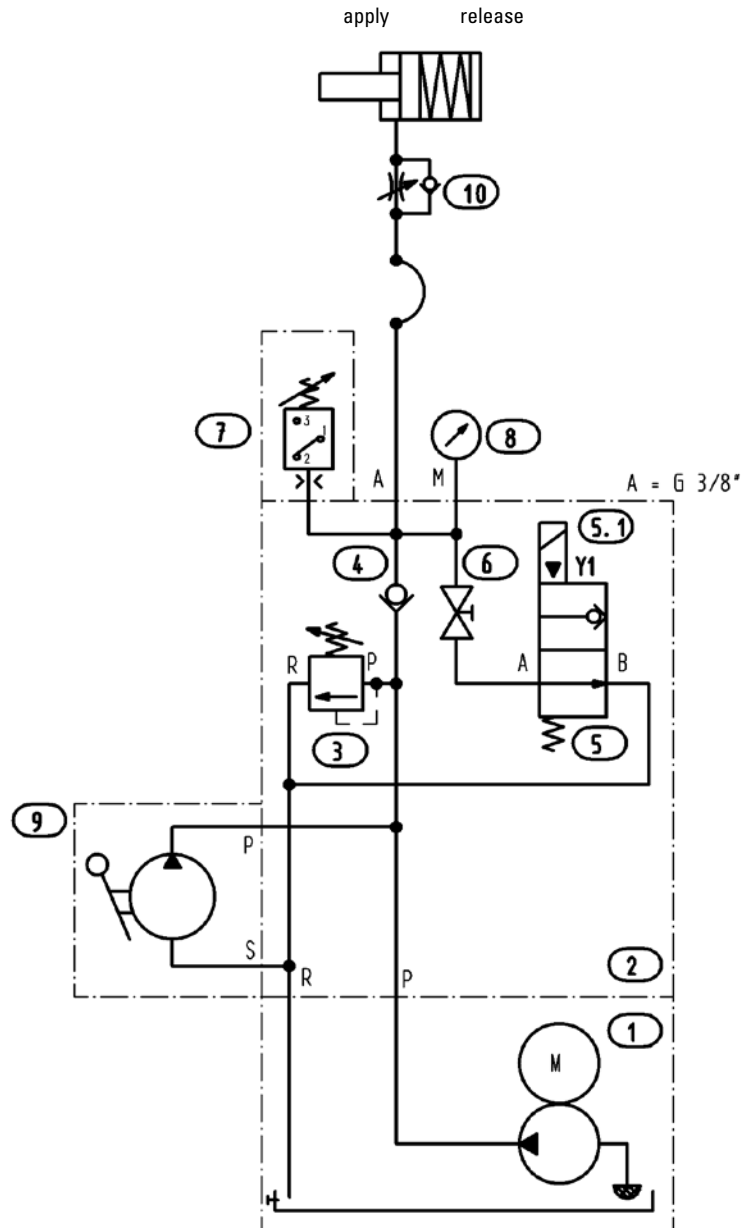

Pos	Qty	Designation
1	1	Hydraulic power unit
2	1	Manifold block
3	1	Pressure valve
4	1	Check valve
5	1	2/2 valve
5.1	1	Plug
6	1	Cock
7	1	Pressure switch
8	1	Pressure gauge
9	1	Hand pump
10	1	Throttle check valve

Alterations reserved without notice

Rail Clamp BSZ

Electric diagram



Rev. 09-02

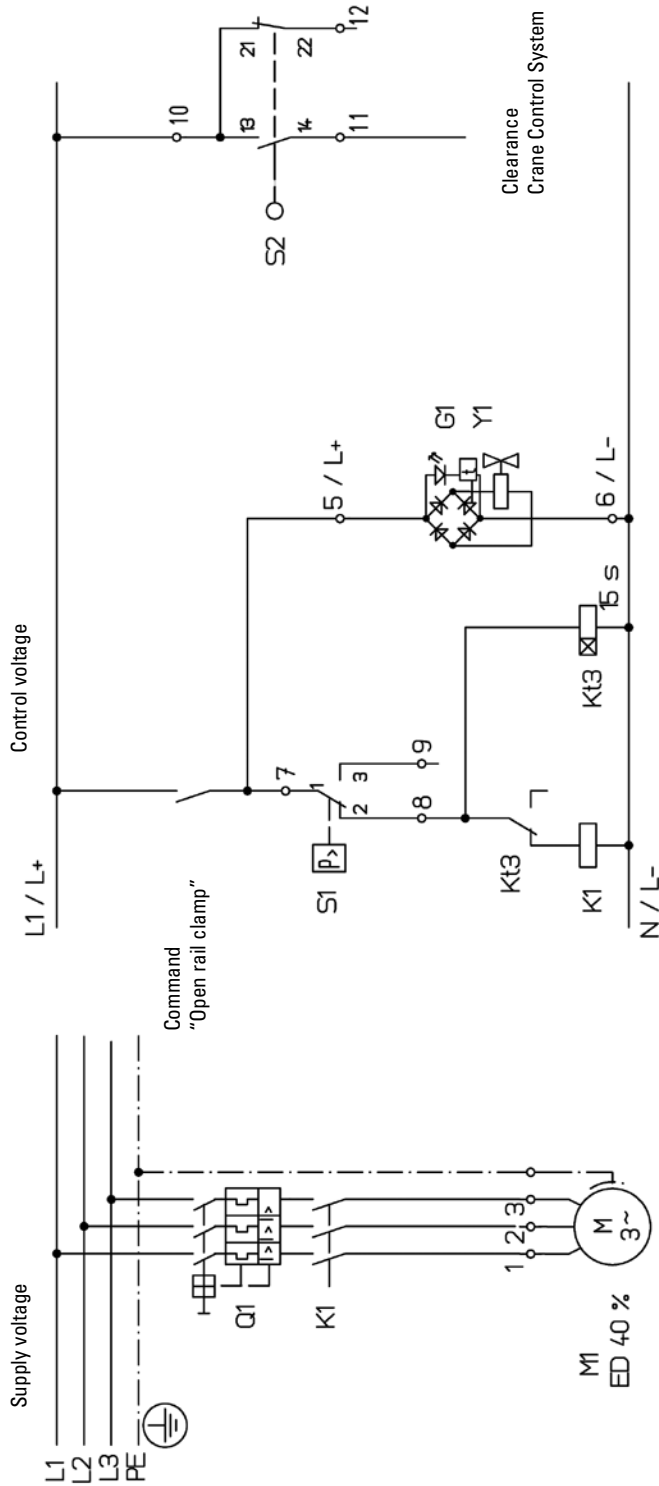

PINTSCH BUBENZER scope of supply	
M1	Hydraulic motor 3 Ph, ED = 40%
Y1	Solenoid valve
G1	Plug
S1	Pressure switch
S2	Limit switch release control

Alterations reserved without notice

Rail Clamp BSZ

Hydraulic diagram



Rev. 09-02

Mounting position buffer and rail sweeper

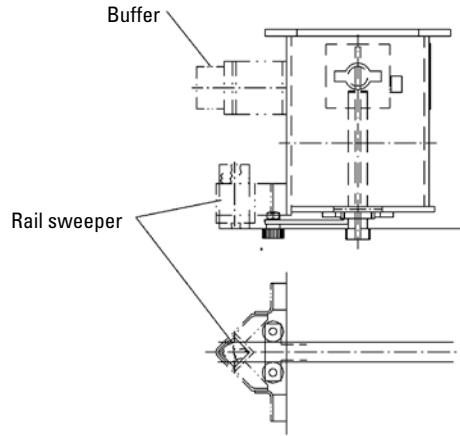

When placing order please indicate buffer dimensions and buffer force.

Mounting position hydraulic power unit

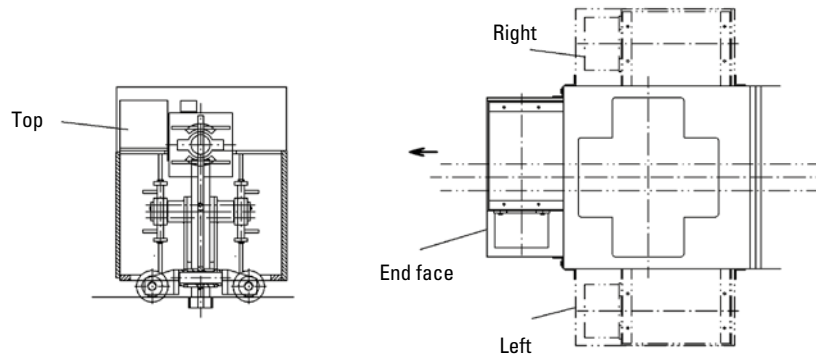

Rail arrangement

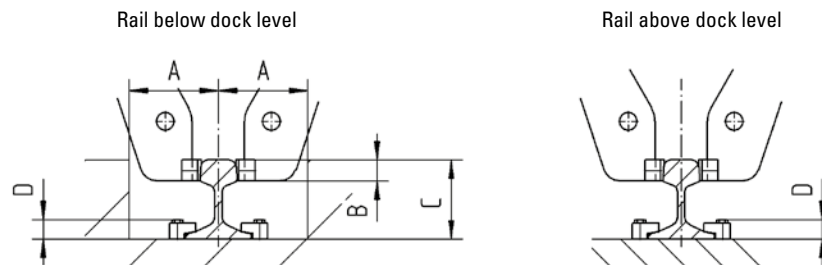

When placing order please indicate dimensions A, B, C and D.

Alterations reserved without notice

Gas-Hydraulic Buffer PB

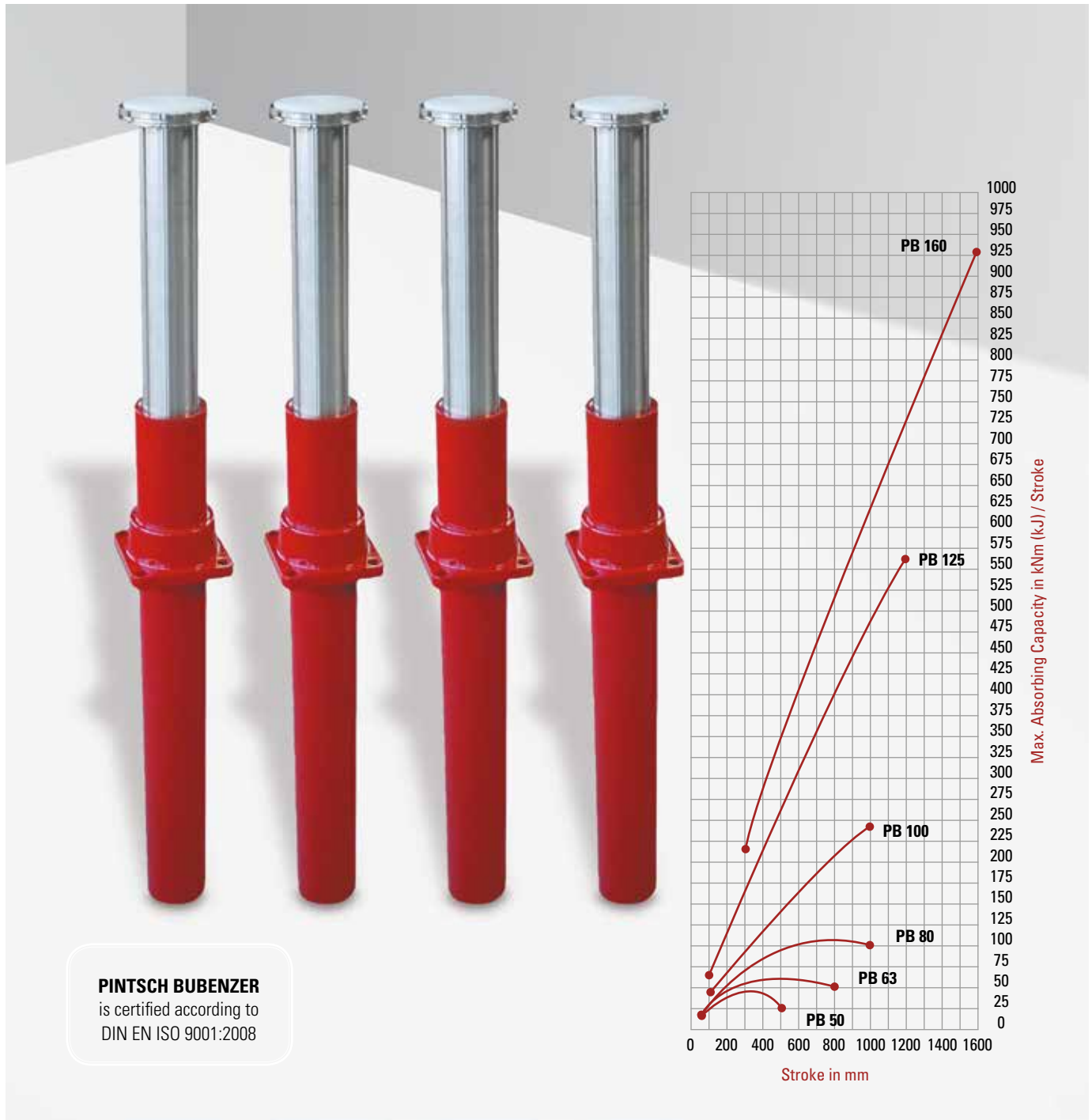

PINTSCH BUBENZER
is certified according to
DIN EN ISO 9001:2008



Reliable



Efficient



Low Maintenance



Robust Construction

Description PB Buffer



Main Features

- Piston and cylinder of special seamless pipes
- Back mounted or front mounted versions available
- Piston rod IONIT-OX coated (plasma nitriding process)
- Impact speed sensitive damping
- Low maintenance

Options

- Special mounting flanges on request
- Special high and low temperature design
- Safety wire rope
- Protection bellows
- Special design on request
- Seawater resistant paint on request

Ordering Example

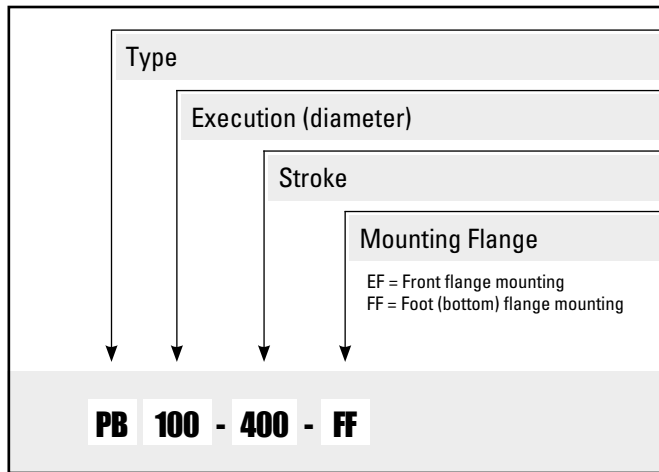

Applications

- As impact energy absorber on crane gantries, trolleys, elevators, stackers, reclaimers and other industrial equipment



Please Note

We supply a detailed operating manual with every order. Nevertheless, we would point out that buffers are only as safe as the servicing and maintenance performed while they are in operation. The guarantee for the correct functioning of our buffers is therefore only valid if the user adheres to the installation and operating manual.



PINTSCH BUBENZER Service

This includes the verification of the brake selection, if required. A detailed questionnaire is provided for this purpose. Installation and commissioning on-site by PINTSCH BUBENZER service engineers is possible. Drawings as DWG/DXF files for your engineering department are available upon request.

Buffer Type PB 50

Dimensions and technical data



Rev. 01-16

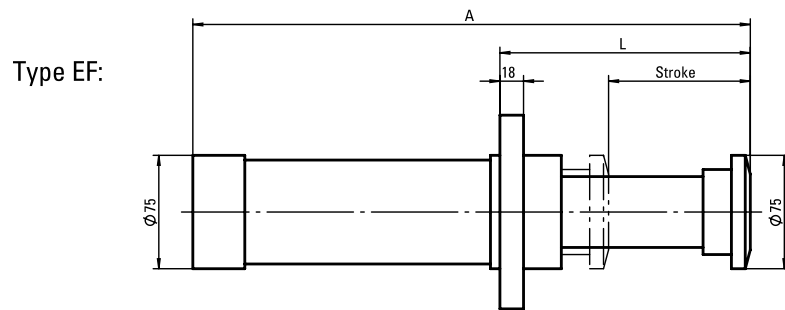
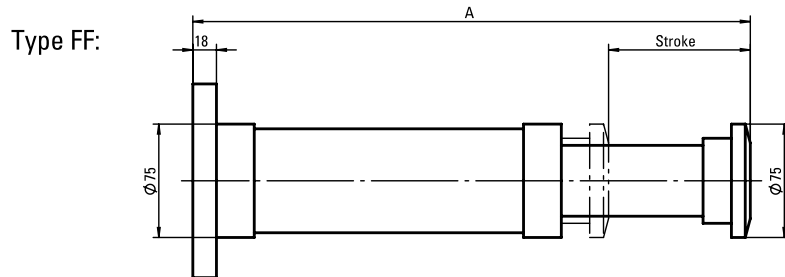

Flange:

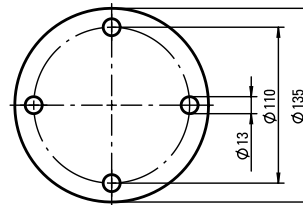

EF = front flange mounting
FF = foot (bottom) flange mounting

All dimensions in mm
Alterations reserved without notice

Stroke	Energy Stroke	* Energy h	Max. buffer force	Inward force	Weight	** Perm. angular deviation	** Perm. angular deviation	A	L
EF FF mm	EF FF kNm (kJ)	EF FF kNm (kJ)	EF FF kN	EF FF kN	EF FF kg	FF degree	EF degree	EF FF mm	EF mm
50	4,5	400	100	5,0	6,6	4,5	5,5	270	145
100	9,0	650	100	6,0	8,2	3,2	4,0	410	195
150	13,6	950	100	6,0	9,8	2,1	2,9	550	245
200	18,1	1250	100	7,0	11,2	1,5	2,3	685	295
250	22,7	1600	100	7,0	12,6	1,3	2,1	825	345
300	27,2	1900	100	7,0	14,0	1,2	1,9	965	395
350	28,6	2000	90	7,0	15,5	1,1	1,8	1105	445
400	29,0	2100	80	7,5	16,9	1,0	1,7	1235	495
450	28,6	2200	70	7,5	18,2	-	1,6	1375	545
500	27,2	2200	60	7,5	19,5	-	1,5	1515	595

* At an ambient temperature of 30°C

** Relating to the max. permissible buffer force

Buffer Type PB 63

Dimensions and technical data



Rev. 02-16

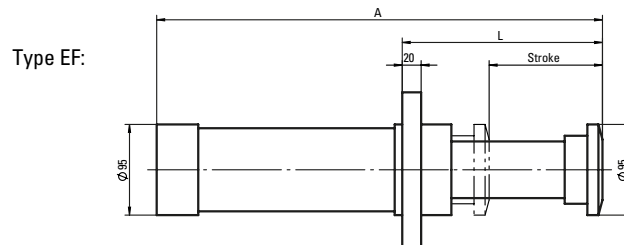
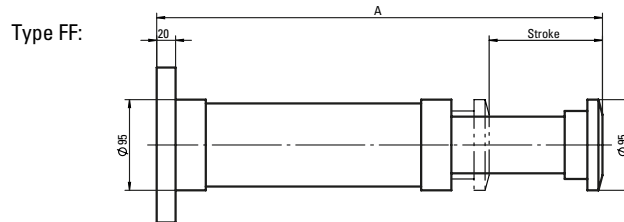

Flange:

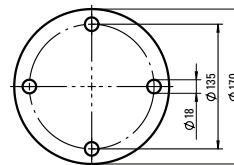

EF = front flange mounting
FF = foot (bottom) flange mounting

All dimensions in mm
Alterations reserved without notice

Stroke	Energy Stroke	* Energy h	Max. buffer force	Inward force	Weight	** Perm. angular deviation	** Perm. angular deviation	A	L
EF FF mm	EF FF kNm (kJ)	EF FF kNm (kJ)	EF FF kN	EF FF kN	EF FF kg	FF degree	EF degree	EF FF mm	EF mm
50	7,7	600	170	8,0	10,5	4,2	5,0	280	155
100	15,4	1200	170	8,0	13,5	3,2	4,0	425	205
150	23,1	1600	170	9,0	16,0	2,2	3,0	560	255
200	30,9	1850	170	10,0	18,0	1,8	2,4	700	305
250	38,6	2100	170	11,0	20,5	1,6	2,2	835	355
300	46,3	2400	170	11,0	23,0	1,5	2,1	975	405
350	50,9	2600	160	12,0	25,5	1,4	2,0	1115	455
400	54,5	2800	150	12,0	28,0	1,3	1,9	1255	505
450	57,2	2900	140	12,0	30,5	1,2	1,8	1395	555
500	59,0	3000	130	12,0	33,0	1,1	1,6	1535	605
550	60,0	3000	120	15,0	35,0	-	1,5	1650	655
600	60,0	3000	110	15,0	37,0	-	1,4	1785	705
650	59,0	3000	100	15,0	39,5	-	1,3	1925	755
700	57,2	3200	90	15,0	42,0	-	1,2	2060	805
750	54,5	3200	80	15,0	44,5	-	1,1	2200	855
800	50,9	3200	70	15,0	47,0	-	1,0	2340	905

* At an ambient temperature of 30°C

** Relating to the max. permissible buffer force

Buffer Type PB 80

Dimensions and technical data



Rev. 02-16

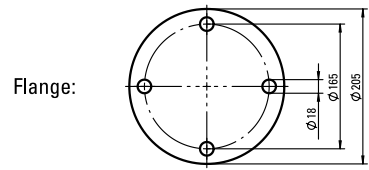
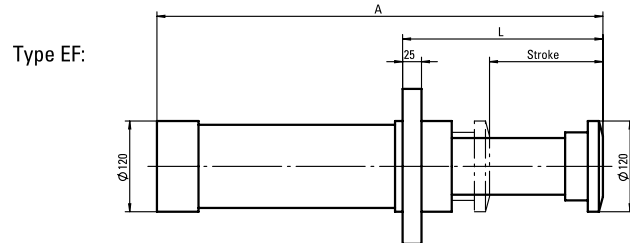
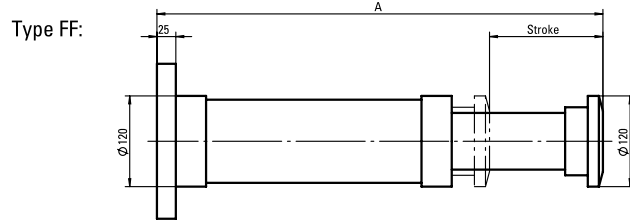

EF = front flange mounting
FF = foot (bottom) flange mounting

All dimensions in mm
Alterations reserved without notice

Stroke	Energy Stroke	* Energy h	Max. buffer force	Inward force	Weight	** Perm. angular deviation	** Perm. angular deviation	A	L
EF FF mm	EF FF kJ	EF FF kJ	EF FF kN	EF FF kN	EF FF kg	FF degree	EF degree	EF FF mm	EF mm
50	11,8	600	260	12,0	20	4,2	5,5	290	175
100	23,6	1000	260	12,0	24	24	4,8	440	225
150	35,4	1700	260	12,0	28	28	4,0	590	275
200	47,2	2200	260	12,0	33	33	3,2	740	325
250	59,0	2600	260	15,0	36	36	2,8	870	375
300	68,1	2800	250	15,0	40	40	2,5	1015	425
350	76,3	3000	240	15,0	45	45	2,2	1160	475
400	83,6	3200	230	17,0	48	48	2,0	1285	525
450	90,0	3500	220	17,0	52	52	1,8	1430	575
500	95,4	3800	210	17,0	56	56	1,6	1570	625
550	100,0	4000	200	17,0	60	60	1,5	1715	675
600	103,6	4200	190	17,0	65	65	1,4	1860	725
650	106,3	4300	180	17,0	69	69	1,3	2000	775
700	108,1	4400	170	17,0	73	73	1,2	2145	825
750	109,0	4400	160	17,0	76	76	1,1	2290	875
800	109,0	4500	150	20,0	79	79	1,0	2395	925
900	106,3	4500	130	20,0	88	88	0,9	2685	1025
1000	100,0	4500	110	20,0	96	96	0,8	2970	1125

* At an ambient temperature of 30°C
** Relating to the max. permissible buffer force

Buffer Type PB 100

Dimensions and technical data



Rev. 02-16

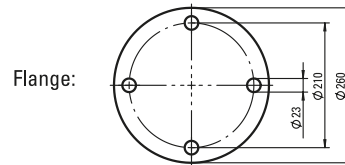
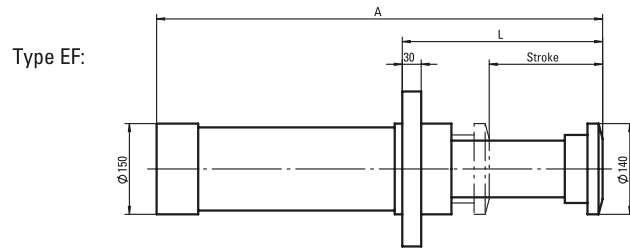
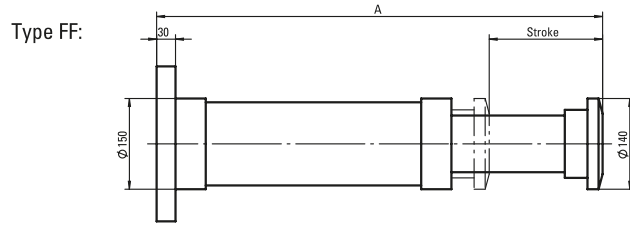

EF = front flange mounting
FF = foot (bottom) flange mounting

All dimensions in mm
Alterations reserved without notice

Stroke	Energy Stroke	* Energy h	Max. buffer force	Inward force	Weight	** Perm. angular deviation	** Perm. angular deviation	A	L
EF FF mm	EF FF kNm (kJ)	EF FF kNm (kJ)	EF FF kN	EF FF kN	EF FF kg	FF degree	EF degree	EF FF mm	EF mm
100	39	1700	430	20	42	5,0	6,0	460	255
150	59	2300	430	20	49	4,5	5,2	600	305
200	78	2750	430	25	57	4,0	4,5	735	355
250	98	3300	430	25	63	3,5	4,0	875	405
300	117	4000	430	25	70	3,0	3,5	1015	455
350	134	4800	420	25	77	2,2	3,0	1165	505
400	149	5500	410	30	84	1,8	2,5	1280	555
450	163	5850	400	30	90	1,6	2,2	1420	605
500	177	6150	390	30	95	1,4	2,0	1560	655
550	190	6450	380	30	100	1,2	1,9	1695	705
600	202	6700	370	30	106	1,0	1,8	1840	755
650	212	7000	360	30	112	-	1,7	1980	805
700	222	7300	350	30	117	-	1,6	2120	855
750	232	7600	340	30	123	-	1,5	2260	905
800	240	7800	330	30	129	-	1,4	2400	955
900	245	8000	300	30	144	-	1,2	2675	1055
1000	245	8200	270	30	160	-	1,0	2955	1155

* At an ambient temperature of 30°C

** Relating to the max. permissible buffer force

Buffer Type PB 125

Dimensions and technical data



Rev. 02-16

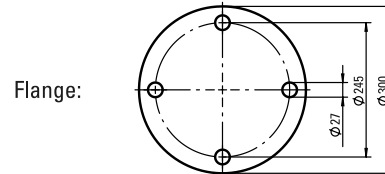
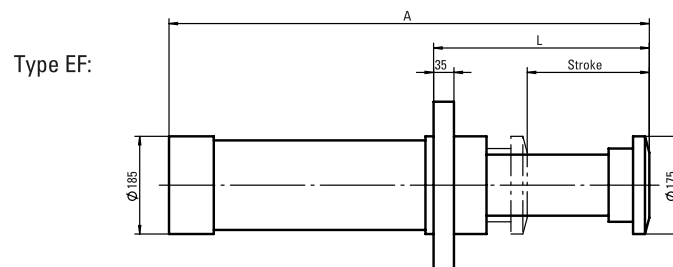
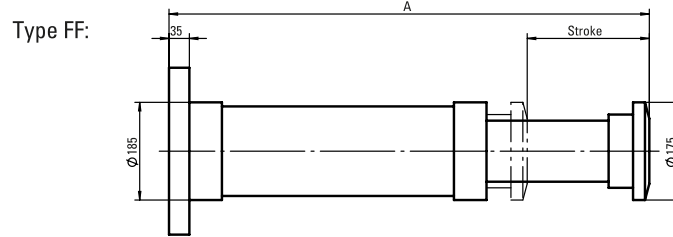

EF = front flange mounting
FF = foot (bottom) flange mounting

All dimensions in mm
Alterations reserved without notice

Stroke	Energy Stroke	* Energy h	Max. buffer force	Inward force	Weight	** Perm. angular deviation	** Perm. angular deviation	A	L
EF FF mm	EF FF kJ	EF FF kJ	EF FF kN	EF FF kN	EF FF kg	FF degree	EF degree	EF FF mm	EF mm
100	62	1800	680	55	60	5,5	6,5	470	251
150	93	2700	680	55	72	5,0	6,0	590	301
200	124	3500	680	55	83	4,4	5,4	730	351
250	155	4300	680	55	95	3,8	4,8	870	401
300	185	5000	680	60	108	3,0	4,0	1000	451
400	247	6500	680	60	133	2,2	3,2	1270	551
500	300	7300	660	60	148	1,5	2,8	1550	651
600	349	8000	640	70	162	1,0	2,4	1800	751
700	394	9000	620	80	182	-	2,2	2050	851
800	436	10000	600	90	198	-	2,0	2300	951
900	474	11000	580	90	215	-	1,8	2560	1051
1000	509	12000	560	90	230	-	1,6	2830	1151
1200	567	13000	520	95	260	-	1,2	3350	1351

* At an ambient temperature of 30°C
** Relating to the max. permissible buffer force

Buffer Type PB 160

Dimensions and technical data



Rev. 02-16

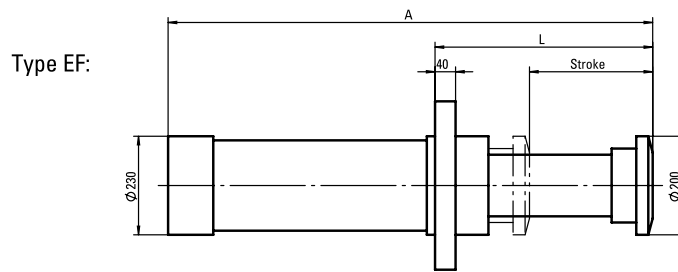
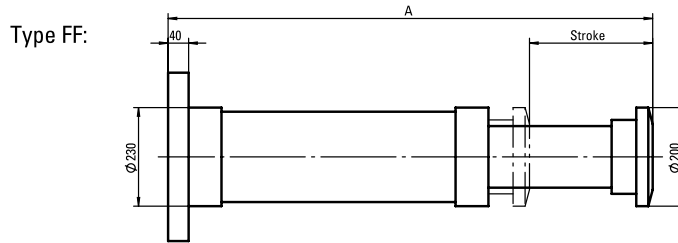

Flange:

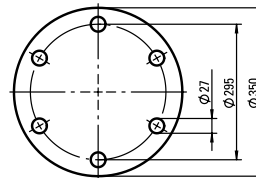

EF = front flange mounting
FF = foot (bottom) flange mounting

All dimensions in mm
Alterations reserved without notice

Stroke	Energy Stroke	* Energy h	Max. buffer force	Inward force	Weight	** Perm. angular deviation	** Perm. angular deviation	A	L
EF FF mm	EF FF kNm (kJ)	EF FF kNm (kJ)	EF FF kN	EF FF kN	EF FF kg	FF degree	EF degree	EF FF mm	EF mm
300	218	5800	800	85	175	2,4	4,0	1080	420
400	290	7000	800	85	206	2,2	3,5	1370	520
500	363	8300	800	85	237	1,8	3,2	1660	620
600	436	9500	800	85	268	1,3	3,0	1950	720
700	509	10500	800	85	299	-	2,8	2240	820
800	581	11500	800	85	330	-	2,6	2530	920
900	638	12000	780	90	361	-	2,4	2820	1020
1000	690	13500	760	90	391	-	2,2	3100	1120
1100	740	14200	740	120	407	-	2,0	3300	1220
1200	785	15000	720	160	427	-	1,8	3500	1320
1300	827	15300	700	160	454	-	1,6	3780	1420
1400	865	15700	680	160	481	-	1,4	4050	1520
1500	900	16000	660	160	511	-	1,2	4330	1620
1600	930	17000	640	160	539	-	1,0	4600	1720

* At an ambient temperature of 30°C

** Relating to the max. permissible buffer force

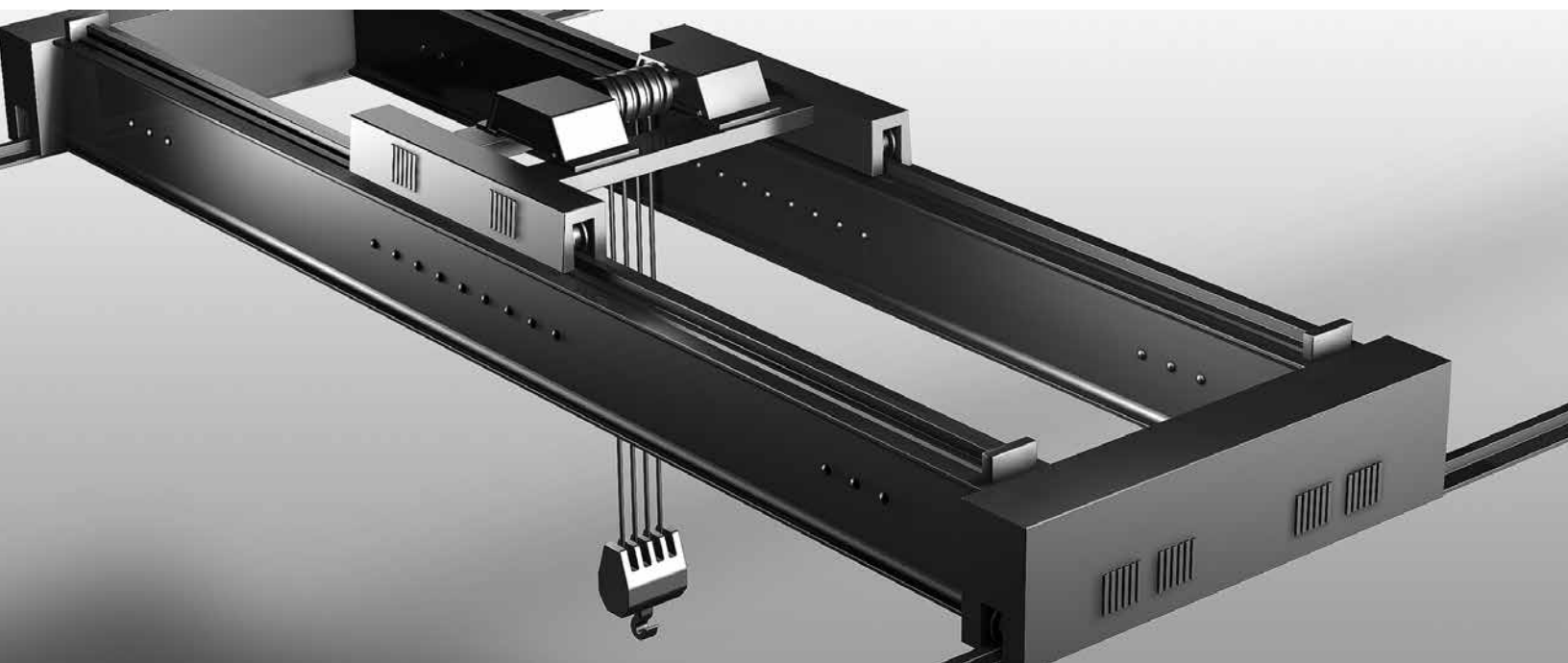

PINTSCH BUBENZER USA LLC

Bartles Corner Business Park
8 Bartles Corner Road, Suite 102
Flemington, NJ, 08822

Tel: +1-908-237-9400
Fax: +1-908-237-9403

info@pintschbubenerusa.com
www.pintschbubenerusa.com

PINTSCH BUBENZER
A Schaltbau Company